



Intellispec™ Hardware Guide Vision Processor S6810

MANUAL PART NUMBER: 86393 REV. 01

HARDWARE PART NUMBER(S): 85577 - 85580

Copyright Notice / Contact Us

© 2025 Pressco Technology Inc. All rights reserved.

No part of this manual may be reproduced or transmitted in any form or by any means, electronic or mechanical, including photocopying and recording, for any purpose, without the express written permission of Pressco Technology Inc.

The contents of this manual are furnished for informational use only, are subject to change without notice, and should not be construed as a commitment by Pressco Technology Inc.

Written and designed at:

Pressco Technology Inc. World Headquarters

29200 Aurora Road

Cleveland, OH USA 44139-1847

TEL +1-440-498-2600

FAX +1-440-498-2615

www.pressco.com

Business Hours: Monday - Friday, 8:00am - 5:00pm Eastern Time

Customer Support:

Request technical support and remote support: techsupport@pressco.com

24/ 7 Customer Support (for urgent system help): +1-440-498-2000

e-mail: Schedule a service visit: dispatch@pressco.com

Request technical support and remote support: techsupport@pressco.com

Customer Service Fax: +1-440-498-4761

Table of Contents

Chapter 1 Pressco Introduction	6
About This Manual	6
Cabinet Part Numbers that this Manual Covers	7
Safety Considerations	8
Static Discharge Protection	8
Chapter 2 Safety Information	9
Health Warning - Photosensitive Epilepsy	9
Symbols Used With This System	10
Arc Welding Warning	11
Label Description - Intellispec	11
Warning Devices	12
Light Tree	12
Residual Risk	12
Intended Use	12
Prohibited Use	13
Personal Protective Equipment	13
Personnel Safety	13
Lifting Heavy Objects	15
Authorized Users	15
Spare Parts Usage	16
Chapter 3 System Specifications	17
Environmental Conditions	17
Sound Pressure Level	17
Electrical Specifications - Vision Processor	18
Dimensions - Intellispec Vision Processor	18
Weight - Vision Processor	21

Chapter 4 Declaration of Conformity - Vision Processor Series 6	22
Chapter 5 Installation	24
Shipping and Handling	24
Recommendations Prior to Installation	24
Utilities to be Supplied by Customer	25
Protective Earthing	25
Electrical Connections	26
Reject Valve Pneumatic Diagram	26
Installation	27
Ventilation	27
Stability of User Interface and Control Cabinet	28
Commissioning	28
Chapter 6 Intellispec Control Enclosure and User Interface	29
Intellispec User Interface	29
Intellispec Vision Processor	29
5-Light Tree (Optional)	30
Power On and Off at the Control Enclosure	32
USB Ports Intellispec Cabinet	32
Biometric Login Device	33
Access the Internal Components with the Power Off	33
Chapter 7 Components and Wiring Diagrams	34
External Connections	34
Included Components	34
Fuse Replacement	36
Wiring Diagram - Sub-Assembly DC Power	37
Wiring Diagrams - Standard Cabinet	38
Wiring Diagrams - Wash-Down Cabinet	46

Chapter 8 Troubleshooting	54
Reboot the Intellispec System	54
Chapter 9 Extended I-O S6	56
Extended I-O Board S6	56
Extended I-O Signals S6	57
Extended I-O Switch SW1 Selection	64
Extended I-O Circuits S6	65
Extended I-O Configuration	66
Chapter 10 Maintenance Frequency	70
Maintenance	72
Clean the Air Conditioner Filter	73

Chapter 1 Pressco Introduction

Welcome!

Congratulations on your purchase of an Intellispec system! The Intellispec is a high-speed machine vision system designed specifically for product and online process monitoring. It is a powerful tool that provides inspection much more reliably than the human eye or sampling methods. The latest PC technology, powerful inspection algorithms, online adjustment capability, and inspection data storage allow the Intellispec to automatically inspect parts with extreme accuracy on high-speed lines.

The Intellispec will help you provide the highest quality of products shipped to your customers.

About This Manual



IMPORTANT: *Keep this manual for future reference*

This book is considered an integral part of the system and should be kept handy for future reference as long as the system is being used in your plant.

The purpose of this manual is to describe the Intellispec Vision Processor and associated hardware. It is intended for trained users.

This manual:

- Is your responsibility to keep in good condition, in a dry place, and ready for consultation by the authorized users of the system.
- Contains the technology implemented at the time of selling and supplying the system and shall not be considered inadequate in case of technological enhancements in the machine or in the manual's illustrations.

Related books include:

- Intellispec Operator's Guide which has Operator-level user instructions, and is a good place to start if you are new to Intellispec
- Intellispec Software Guide which has Administrator-level user instructions
- Inspection module addenda that contain hardware information specific to those inspection modules

The following types of alerts may appear in this guide:



DANGER! - *Danger messages alert you to specific conditions that can cause serious or fatal personal injury. Danger messages give you important information which must be observed to prevent injury.*



WARNING: - *Warning messages indicate information which must be observed to prevent injury, data loss, or equipment damage.*



CAUTION - *Caution messages indicate important information which must be observed to prevent: loss of data, poor system performance, or equipment damage.*

Note: Notes contain special information that warrants being set off from the body text as shown here.

! *IMPORTANT - Indicates prerequisites or information that must be observed to complete or understand a concept or task.*

TIP: Provides helpful hints for completing a task.

Cabinet Part Numbers that this Manual Covers

This manual is for Intellispec Series 6S Vision Processor control cabinets. These cabinets all use **model 6810**. Model 6810 cabinets have a **maximum number of eight lanes**, and a **maximum number of 10 cameras** supported.

There are four Pressco part numbers that are part of the Series 6S model 6810 cabinets. The internal components are similar.

Refer to your Serial Number label to determine which cabinet you have. The wiring diagrams in this manual are indicated by Family Drawing numbers.

Your cabinet may have the monitor and keyboard attached or separate, and could look like one of the following pictures:

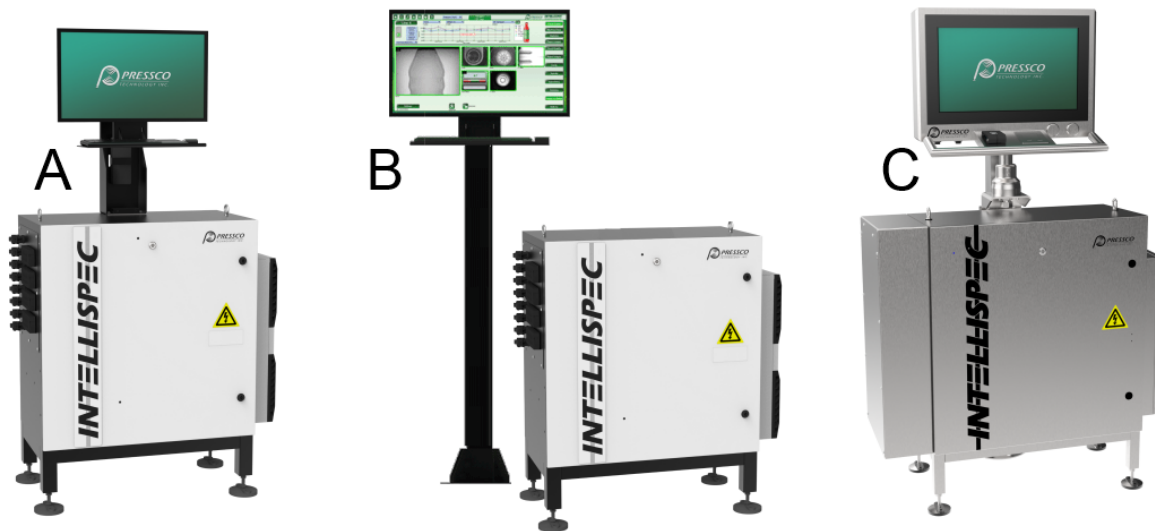

Pressco Part Number	Standard Cabinets [A and B]	Family Drawing
85577	Assembly Vision Processor 8 Lane 120V	F2305
85578	Assembly Vision Processor 8 Lane 230V	
Wash Down Cabinets [C]		
85579	Assembly Vision Processor 8 Lane 120V Wash-down	F2306
85580	Assembly Vision Processor 8 Lane 230V Wash-down	

Safety Considerations

Observe the following safety warnings when operating the system or working near it:



WARNING - Potential for projectiles to strike persons and cause injury. Keep clear of reject devices.



WARNING - Sensitive electronics and High Voltages may be exposed. Keep Processor Cabinet/ Electrical Control Box door closed.

Static Discharge Protection



Caution - Electronic components can be damaged by static electricity discharge.

Always observe the following precautions before removing, installing or handling any electronic components within the Inspection System:

- Wear an anti-static wristband which is grounded to the Inspection System.
- Stand on an anti-static, grounded floor mat, and lay circuit boards on the mat during any board replacement.
- Keep circuit boards in static shield bags when storing and transporting. Ensure the bag is sealed.

Chapter 2 Safety Information

This section contains operator safety information that must be read before operating or servicing the system.

 **WARNING** - This product contains no operator serviceable parts. Refer servicing to qualified personnel. To prevent electrical shock do not open cabinet doors whilst power is connected.

 **WARNING** - Do not, under any circumstances, tamper with sealed machine parts or devices. This could result in the removal of protections that might create potentially hazardous conditions.

 **CAUTION** - Possible hazardous optical radiation from LEDs. Do not stare at lamps.

Observe the following safety warnings when operating the system or working near it:

 **WARNING** - Potential for projectiles to strike persons and cause injury. Keep clear of reject devices.

 **WARNING** - Sensitive electronics and High Voltages may be exposed. Keep Processor Cabinet/ Electrical Control Box door closed.

Health Warning - Photosensitive Epilepsy

 **WARNING: PHOTSENSITIVE EPILEPSY/ SEIZURES**

A small percentage of individuals may experience epileptic symptoms or seizures when exposed to certain patterns or flashing lights. Exposure to the flashing lights in vision inspection systems may also trigger epileptic symptoms or seizures in these individuals. These flashing lights may trigger epileptic symptoms or seizures in persons who have no history of epileptic symptoms or seizures. If you, or anyone in your family has an epileptic condition or has had seizures of any kind, consult your physician before operating this machinery.

IMMEDIATELY DISCONTINUE use and consult your physician if you experience any of the following symptoms while operating this machinery:

- Dizziness
- Altered vision
- Eye or muscle twitches
- Loss of awareness
- Disorientation
- Seizures
- Any involuntary movement or convulsion

Epileptic symptom or seizure triggers vary from person to person. Some common triggers are:











- Flashing lights used for vision inspection systems or fire alarms
- Certain video games or TV broadcasts containing rapid flashes or alternating patterns of different colors
- Bright, contrasting patterns such as white bars against a black background
- Flashing white light followed by darkness
- Stimulating images that take up your complete field of vision, such as being very close to a TV screen or computer monitor
- Certain colors, such as red and blue



If you encounter something that might trigger epileptic symptoms or seizures without warning:

- Do not close your eyes (this could cause a flicker effect)
- Do not look directly at the flashing lights or trigger source
- Do cover one eye with the palm of your hand immediately
- Do turn away from the flashing lights or trigger source

Symbols Used With This System

The following symbols are used on or near the Pressco system. Be aware of potential risk hazards.

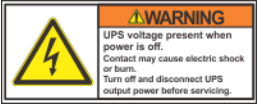
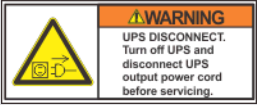
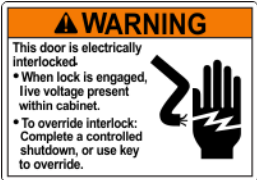
Symbol	Meaning
	CAUTION: Risk of danger. Refer to accompanying user documentation before use.
	WARNING: Risk of electric shock
	WARNING: Arc flash and shock hazard
	WARNING: Risk of electrical shock
	WARNING: Risk of burns from hot surface
	WARNING: Hand crush hazard
	On (supply)
	Off (supply)
	Alternating current
	Protective conductor terminal

	<p>Warning: Arc flash and shock hazard</p>
	<p>Warning: UPS voltage present when power is off</p>
	<p>Warning: UPS Disconnect</p>
	<p>Warning: Electrical interlock</p>
	<p>Danger: shock and arc flash explosion hazards</p>

Arc Welding Warning

⚠ WARNING - Potential equipment damage can occur if the vision equipment is not fully powered down prior to any arc welding performed on the line where the vision equipment is installed, specifically but not limited to our encoders.

Label Description - Intellispec

The following illustration shows an **example** label that you will find on the Intellispec system components.

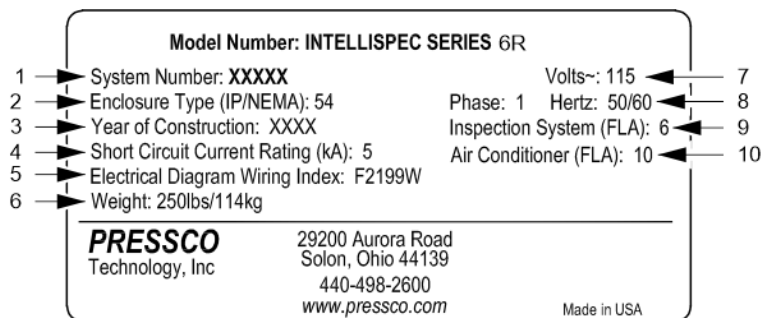

- 1) System Number/ Serial number
- 2) Enclosure type
- 3) Year of construction
- 4) Short circuit current rating

Chapter 2

- 5) Wiring diagram reference
- 6) Weight
- 7) Voltage range in Volts AC
- 8) Frequency
- 9) Full load current for inspection system
- 10) Full load current for air conditioner

Warning Devices

The Pressco system has warning devices that indicate system failure or report excessive defects or warnings for your production line. These include an optional light tree, alarms and indicators on screen, and audible warnings (depending on system).

Light Tree

The optional light tree is mounted on a pole in a customer-specified location.



The light tree color segments represent each alarm or system condition. A color segment may appear for more than one alarm condition.

Residual Risk

The Pressco system has been designed to minimize any danger of personal injury. However, the system uses rejection devices to remove defective product from the production stream. Also, the electronics cabinets contain risk of shock if they are opened.

Observe the following safety warnings when operating the system or working near it:



WARNING - Potential for projectiles to strike persons and cause injury. Keep clear of reject devices.



WARNING - Sensitive electronics and High Voltages may be exposed. Keep Processor Cabinet/ Electrical Control Box door closed.

Intended Use

Type of Process - The Pressco system is intended to monitor container and other special manufacturing processes and identify non-conforming product.

Intended Use - The Pressco system is designed and constructed for use in an indoor industrial environment, always sheltered from the weather.



Space Required - The Pressco system and accompanying sensors must be installed in a place that will enable safe and easy installation, size changeover, user operation, and maintenance procedures.

Prohibited Use

 **WARNING** - If this instrument is not used as specified, the protection provided by the equipment could be impaired. This instrument must only be used in a normal condition (in which all means of protection are intact).

 **Important** - The Pressco system should NOT be used for any purpose other than specifically indicated in the section titled "**Intended Use**" on the previous page.





The following uses are not intended:

-  Use in an explosive environment
-  Use in a flammable environment
-  Use in a damp, moist, or wet environment, except where specifically indicated

Personal Protective Equipment

 **Important** - Always follow the safety requirements of your plant in addition to the recommendations below.

We recommend, at minimum, use of the following Personal Protective Equipment (PPE):

	Protective clothing
	Protective gloves
	Protective ear plugs or headphones
	Protective eye wear
	Protective foot wear



Personnel Safety

The following rules are recommended to ensure the safety of personnel in charge of machine operation and maintenance.







During machine operation:









Only one operator is needed to operate the machine. All others must keep at a safe distance.

	<p>Operators must be familiar with all machinery connected to the Pressco equipment and know how to use emergency stop devices.</p> <p>Note: the emergency stop devices may not be connected directly to the Pressco equipment, but it is important to know how to use them.</p>
	<p>Before putting the Pressco system online, the operator must ensure that all safety devices used with all connected machinery are in place and operational.</p> <p>Do not operate with guards removed.</p>
	<p>The operator must maintain maximum focus on his work and be alert throughout his shift. If this is not the case, immediately inform the shift supervisor.</p>

When carrying out maintenance or repair work:

	<p>Disconnect master switch. For switch locations, refer to the Power Up and Power Down section.</p>
	<p>Before starting the machine, ensure that no person is close to the machine.</p>
	<p>If maintenance or repair requires the disconnection or removal of safety or protection systems, this operation must be supervised by authorized personnel who must ensure the prevention of personal injury or damage to the machine. All machine movements must be performed with limited speed and limited movements.</p>
	<p>Maintenance or repair work on electrical components must be carried out exclusively by authorized, trained personnel. When running tests with power connected, you must strictly comply with the rules provided.</p>
	<p>Personnel working on higher parts of a machine must wear a harness and hook it on to the structure and must always move with extreme caution.</p>
	<p>Never perform lubrication or maintenance procedures on mechanical parts with the machine running.</p>

For your safety, do not:

-  Open safety guards during machine operation
-  Perform maintenance and repair while the system is running
-  Lean on the machine
-  Sit on the machine components
-  Use the machine for purposes other than those listed in this manual
-  Modify parts of the machine



Allow unqualified personnel to operate or perform maintenance procedures on the machine

Lifting Heavy Objects



CAUTION - Some components are heavy. Take proper precautions to prevent personal injury or damage to equipment. If you are not capable of lifting the object alone, ask a capable person to help lift the object, or use a mechanical lifting device

The components do not have handles to lift the equipment. Be sure to:

- Lift equipment from the bottom - do not use wires, brackets, nor other protrusions
- Keep fingers away from sensor lenses to keep the equipment clean
- Proceed slowly



WARNING- The Pressco cabinets must NOT be lifted by one person. Use a mechanical lifting device, and ask another person to assist you.



Do not twist your body when moving the load. Instead take small steps with your feet turning until you are in the correct position.

To safely lift equipment:

1. Stand close to the load and center yourself over it with your feet shoulder width apart.
2. Tighten your abdominal muscles.
3. Keeping your back straight, bend your knees and squat down to the floor.
4. Get a good grasp on the load with both hands.
5. Keeping the load close to your body, use your leg muscles to stand up lifting the load off the floor. Your back should remain straight throughout lifting, using only the muscles in the legs to lift the load.
6. To place the load in the appropriate spot, bend at the knees using only your leg muscles to lower the load.

Authorized Users

Trained machine operators, mechanic and electrical maintenance staff, and plant managers are considered authorized users of the Pressco system. These users should carefully read the information contained in this manual. The plant manager must ensure that the safety recommendations included in this manual are observed.



WARNING - Allowing workers who are unfamiliar with the production process to operate the Pressco system could result in hazard risk.

If you are unclear about any part of this manual, contact Pressco Technical Support.



Important - No worker should ever operate the system outside of his/ her own area of competence and responsibility.

Proper Operation - Only one worker is to operate the system at any given time. The correct position for the operator is in front of the user interface monitor or control enclosure (if applicable).

Repairs - Any repair on the system shall be carried out exclusively by Pressco Technology Inc. service personnel or by other service expressly authorized by Pressco Technology Inc.

Spare Parts Usage

The following restrictions apply to replacing parts:



WARNING - Using spare parts that are not designed to Pressco's specifications can compromise the safety and effectiveness of the Pressco system.

- The use of parts that are not within Pressco's design specifications is prohibited. This prohibition applies in particular when the parts involved contain or are connected with safety devices.
- Before resuming production, make sure all safety devices are in working order.

Pressco Technology Inc. shall not be liable in any way if any of the above-described directions are not complied with.

To obtain a spare parts list, contact the Spare Parts department at Pressco: SpareParts@pressco.com. Or call +1-440-498-2000 (Monday - Friday 8AM - 5PM Eastern time).

In addition, Pressco's technicians are available to help customers, in their own plant, to solve any problem that might arise during use and maintenance of the system.

Chapter 3 System Specifications

This instrument has been designed and tested in accordance with Publication EN61010-1 (2010) Safety Requirements for Electrical Equipment for Measurement, Control and Laboratory Use and has been supplied in a safe condition. The instruction documentation contains information and warnings which must be followed by the user to ensure safe operation and to maintain the instrument in a safe condition.

Environmental Conditions

The Intellispec system is designed to be safe in the following environmental conditions:

Note: Please consult Pressco Technology Inc. if your environmental conditions are outside of those listed.

Condition	Specifications
Indoor/ outdoor use	Indoor use only
Altitude	Up to 2000 meters
Operating Temperature	5 °C to 50 °C
Storage Temperature	0 °C to 70 °C
Humidity	Maximum relative humidity 80 % for temperatures up to 31 °C decreasing linearly to 50 % relative humidity at 50 °C
Mains supply	Voltage fluctuations up to ± 10 % of the nominal voltage
Overvoltage protection rating	Transient overvoltage typically present on MAINS supply NOTE: the normal level of transient overvoltages is impulse withstand (overvoltage) category II of IEC 60364-4-443.
Rated pollution degree	This instrument is designed for use in Installation Category II and Pollution Degree 1 as per EN61010-1 and EN60664 respectively.



Warning - This is a Class A product. In a domestic environment this product may cause radio interference in which case the user may be required to take adequate measures.

Sound Pressure Level

The horn on the optional light tree has a maximum 105dB level at 1 meter distance in front of the horn. Use proper hearing protection as specified by your plant safety instructions.

Electrical Specifications - Vision Processor

The following are electrical specifications for the vision processor:

115 VAC Unit	Series 6S Vision Processor	Air Conditioner
Voltage Range	115 VAC	115 VAC
Frequency	60Hz	60Hz
Current (FLA)	8A	6A @ 115VAC, 100% Load
Power Consumption	900W	620W

230 VAC Unit	Series 6S Vision Processor	Air Conditioner
Voltage Range	230 VAC	230 VAC
Frequency	50/60Hz	50/60Hz
Current (FLA)	4A	2.7A @ 230VAC, 100% Load
Power Consumption	900W	620W

Dimensions - Intellispec Vision Processor

The measurements are in inches. The numbers in brackets are in millimeters.

Standard Cabinets

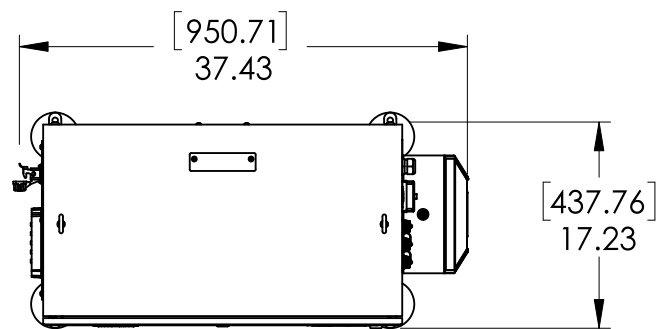
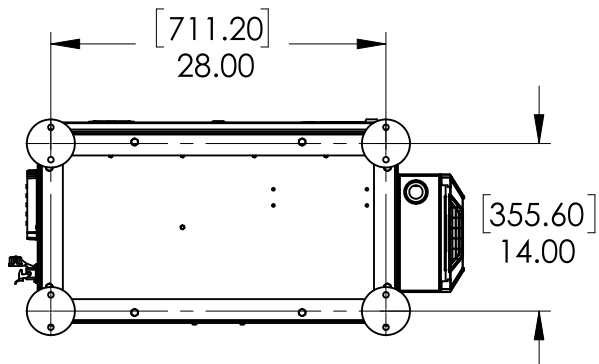
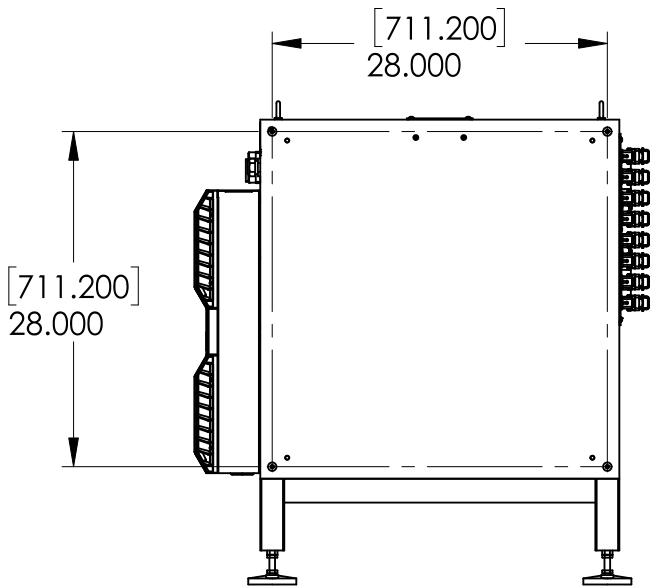
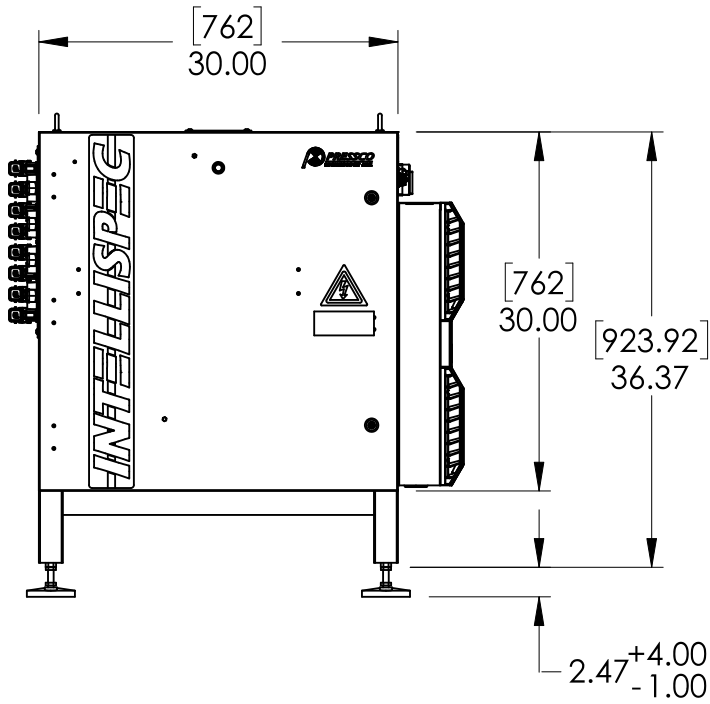

Wash-Down Cabinets

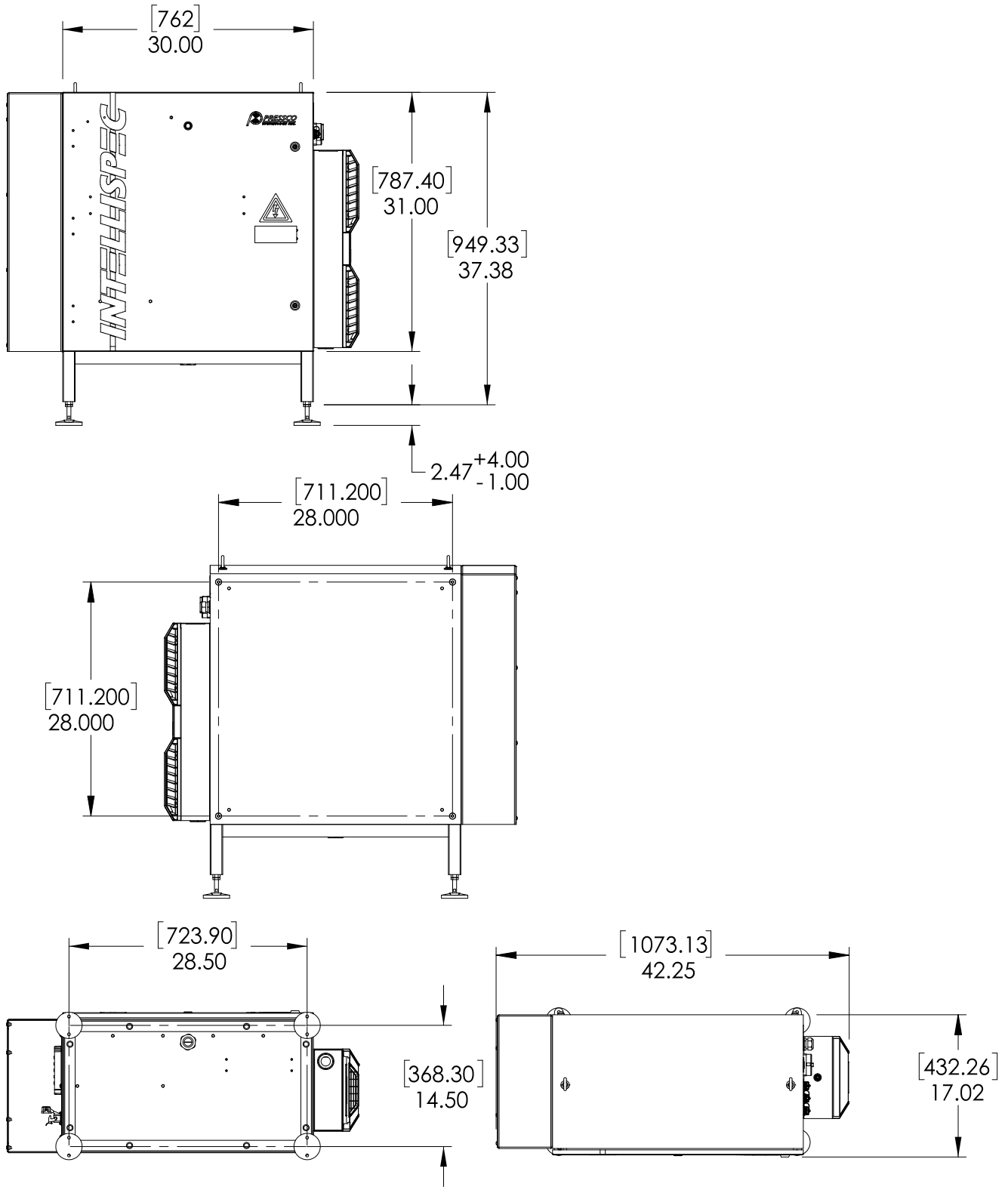

Weight - Vision Processor

The weight of a crate is listed below. Note that this is the maximum weight. The weight may be less depending on your configuration. You may receive multiple crates depending on your configuration.

Weight (full Intellispec 6S system)	250 lbs. (114 kg)
-------------------------------------	-------------------

Chapter 4 Declaration of Conformity - Vision Processor Series 6

Declaration	<p>The listed product is in conformity with following Union harmonization legislation:</p> <p>Directive 2014/30/EU of the European Parliament and of the Council of 26 February 2014 on the harmonisation of the laws of the Member States relating to electromagnetic compatibility and with Directive 2014/35/EU of the European Parliament and of the Council of 26 February 2014 on the harmonisation of the laws of the Member States relating to the making available on the market of electrical equipment designed for use within certain voltage limits.</p> <p>The Technical Documentation demonstrates the fulfillment of the essential requirements as set out in Annex I of the above Directive.</p>
Manufacturer	<p>Pressco Technology Inc. 29200 Aurora Road Cleveland, Ohio 44139-1847 USA</p> <p>This declaration of conformity is issued under the sole responsibility of the manufacturer.</p>
Product Name	Intellispec Series 6 Models S6406, S6810, S6816
Referenced harmonised standards to which conformity is declared:	<p>EN 61326-1:2013 Electrical equipment for measurement, control and laboratory use — EMC requirements — Part 1: General requirements</p> <p>EN 55011:2016+A11:2020: Radiated / Conducted Emissions</p> <p>EN 61000-4-2:2009: ESD Immunity</p> <p>EN 61000-4-3:2006 + A1:2008 + A2:2010: Radiated RF Immunity</p> <p>EN 61000-4-4:2004 + A1:2010: EFT Burst Immunity</p> <p>EN 61000-4-5:2006: Surge Immunity</p> <p>EN 61000-4-6:2009: Conducted RF Immunity</p> <p>EN 61000-4-11:2004: Voltage Dips & Interruptions</p> <p>EN 61010-1:2010 Safety requirements for electrical equipment for measurement, control, and laboratory use - Part 1: General requirements</p> <p>2011/65/EU Restriction of Hazardous Substances in Electronic Equipment</p>
Place	Pressco Technology Inc. 29200 Aurora Road Cleveland, Ohio 44139-1847 USA

Signed: George Hall, VP Engineering. Signed for and on behalf of Pressco Technology Inc.

Chapter 4

Signed for and on behalf of Pressco Technology Inc., 29200 Aurora Road, Cleveland, OH USA 44139:

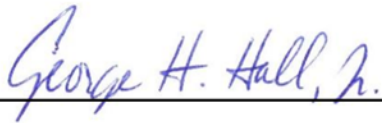

George H. Hall, Jr.

George Hall
VP, Engineering

Date: 12 November 2024

Chapter 5 Installation

This section contains information about installation requirements and preparations that need to be complete before installing the system.

Pressco Technology Inc. recommends that the machine be installed and assembled by Pressco's specialized technicians. This is of vital importance for correct machine operation.

 **WARNING** - Pressco Technology Inc. shall not be liable in case of failures or damage to property and/or personal injury resulting from or connected with assembly if this has been carried out by unauthorized personnel, or is not in compliance with the indications given in this manual.

To carry out production and cleaning/ servicing operations, it is important for the machine to have a minimum amount of space all around and away from walls.

Shipping and Handling

Pressco Technology Inc. ships unassembled components in packing cases designed to protect the contents during handling and from exposure to weather.

Unless otherwise specified in the contract with the machine order, the Customer shall supply Pressco Technology Inc. with the means and equipment necessary for the unloading, lifting, and handling of machine parts. Pressco Technology Inc. deems it important to have one of their technicians supervise the process of unloading, handling, and lifting the machine. The technician can give useful advice as to the logical sequence in which the components should be unpacked and positioned for ease of assembly.

 **WARNING** - Only qualified personnel must be involved in the operation of unloading, handling, and lifting the machine. Pressco Technology Inc. shall not be liable for damage to components and/or personal injury resulting from the involvement of unauthorized personnel and/or failure to comply with the directions provided in this manual in relation to lifting and transport.

 **Important** - The site supervisor will be responsible for ensuring that all the various mounting phases are carried out safely and in compliance with current regulations.

After the machine is delivered, check for any damage that might have occurred during shipping. In case of damage, contact Pressco Technology Inc.

In handling the machine, always keep it close to the ground.



We recommend using a forklift truck with adequate capacity and forks to suit the weight to be lifted (machine plus packaging).

Recommendations Prior to Installation

Before the machine is installed, the Pressco installer, together with the Customer (or representative) shall check the following criteria in the environment where the machine is to be installed:

- Work required by contract for the installation of the machine has been carried out
- The plant layout drawing that describes where the machine will be installed is the final drawing agreed to by Pressco Technology Inc.
- The space and height required for installation are actually available
- Only the components included in the installation layout are present in the area where the machine is to be mounted. Ensure no machines or components have been added at a later stage that might hinder mounting or make it more difficult. Should this be the case, immediately contact Pressco's Project Engineering personnel to arrange a suitable solution to the problem.

We recommend the following prior to machine installation:

- Transport the machine in its packaging to the area where it will be installed to minimize possibility of damage
- Carefully remove the packaging material and check components for damage
- Check tightness of mechanical components, as they can loosen during transport
- Prepare the compressed air mains line. Before making final connections, ensure that the pipes are clean and free from any debris.

Utilities to be Supplied by Customer

The following utilities are required to operate the Pressco Intellispec system. Before making connection, make sure the utility matches the technical specifications. More than one connection of the utilities may be required depending on the number of modules installed. Refer to specific wiring diagrams.

Utility	Requirements
Air supply for rejection device	Pipe size must be such that there will be no pressure decrease during machine operation. Air must be dry and free of oil.
Electrical supply	Provide one each electrical socket to comply with: <ul style="list-style-type: none"> • User interface electrical specifications (use the specifications that apply to your system) • Integrated tunnel electrical specifications (if applicable) • Cluster box electrical specifications (if applicable)
Internet connection (optional)	Provide a shielded ethernet cable to use Pressco's remote support through the Internet.

Protective Earthing

This product must be grounded (earthed). If it should malfunction or break down, grounding provides a path of least resistance for electric current to reduce the risk of electric shock.

 **DANGER** - Improper connection of the equipment grounding conductor can result in a risk of electric shock. Check with a qualified electrician or service technician if you are in doubt as to whether the product is properly grounded.

Cord Connected Equipment

The product will be equipped with a supply cord having an equipment grounding conductor and a grounding plug. The plug must be plugged into an appropriate outlet that is properly installed and grounded in accordance with local codes and ordinances.

Do not modify the plug provided with the product - if it will not fit the outlet, have a proper outlet installed by a qualified electrician.

Cable Direct

This product must be connected to a grounded metal, permanent wiring system, or an equipment grounding conductor must be run with the circuit conductors and be connected to the equipment grounding terminal.

Electrical Connections

Make sure that the power outlet voltage matches the voltage required by the machine. Refer to the electrical specifications and wiring diagrams for your system.



WARNING - Power Switch is the power disconnect device. Do not position the equipment such that access to the disconnect switch is impaired. If not readily accessible (such as within a rack or mounting out of reach), an additional disconnect device should be installed that can isolate the Live and Neutral lines of the mains power supply, whilst leaving the protective earth intact.

Standard cabinets

- Wiring diagram for systems with 115VAC power: "F2305W Sheet 1 of 7" on page 39
- Wiring diagram for systems with 230VAC power: "F2305W Sheet 3 of 7" on page 41

Wash-down cabinets

- Wiring diagram for systems with 115VAC power: "F2306W Sheet 1 of 7" on page 47
- Wiring diagram for systems with 230VAC power: "F2306W Sheet 3 of 7" on page 49

Reject Valve Pneumatic Diagram

This diagram shows the reject device connection to the 8-port I/O box. This is for Intellispec systems.

Chapter 5

8-PORT I/O BOX 57006

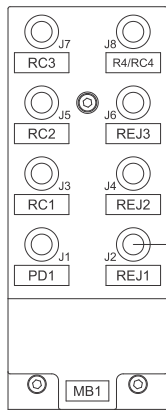

REJECT VALVE PNEUMATIC DIAGRAM

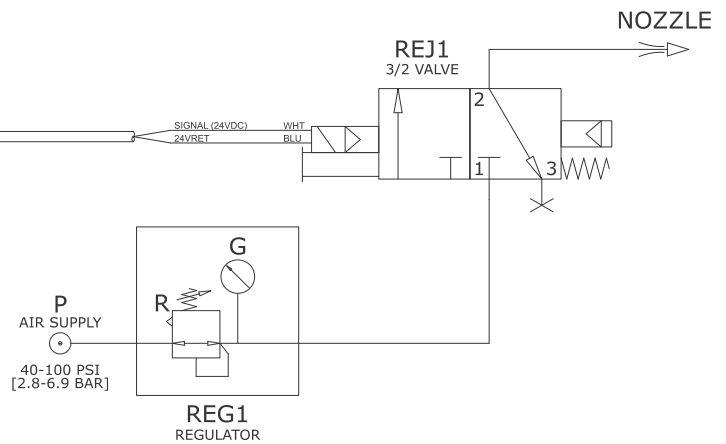

Installation

Pressco Technology Inc. recommends that the machine be installed and assembled by Pressco's specialized technicians. This is of vital importance for correct machine operation.



WARNING - Pressco Technology Inc. shall not be liable in case of failures or damage to property and/or personal injury resulting from or connected with assembly if this has been carried out by unauthorized personnel, or is not in compliance with the indications given in this manual.

To carry out production and cleaning/ servicing operations, it is important for the machine to have a minimum amount of space all around and away from walls.

Ventilation

Place the Pressco Intellispec components in a position with adequate ventilation to allow proper air flow through the air filters.

Component	Spacing
User Interface	Leave 1 meter [39 inches] clear around machine
Cluster box (not used on all systems)	Leave 100 mm clear in front of the fan and vent

Stability of User Interface and Control Cabinet

Install lag bolts through the holes in the base to secure the user interface and control cabinet to the floor.

(bolts shown are for illustration purposes only, and are not included with the system)

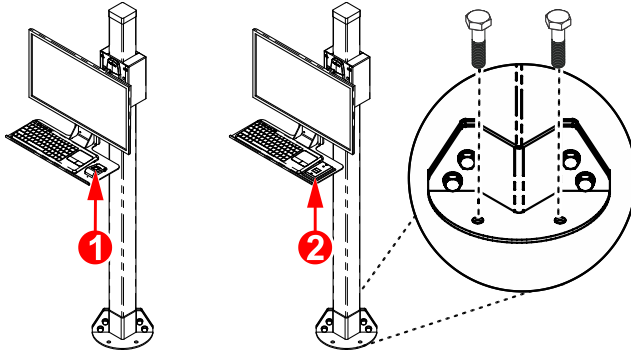

Your system has user interface hardware to operate the system. For logging into the system, your system may have the optional 1) biometric fingerprint reader or 2) RFID card reader. Either way, secure the pole to the ground.

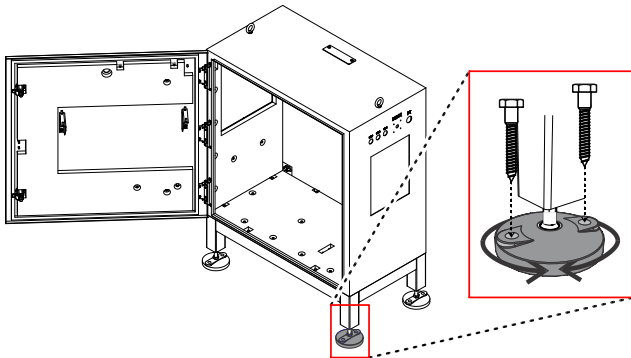

Adjust the feet to level the control cabinet and ensure stability. Proper leveling can help ensure proper operation. Also refer to the directives in the "Personnel Safety" on page 13 section.

Commissioning

Before placing the machine into operation, make sure the following checks are completed:

Completed	Yes	No
Positioning and leveling of the unit		
Connection of compressed air line to connection points		
Connection of power supply to vision processor cabinet		
Connection of power supply to cluster box (if applicable)		
Connection of power supply to integrated inspection module(s) if applicable		
Proper wiring from user interface cabinet to sensor module(s) and cluster box (if applicable) using the wiring diagrams		

Chapter 6 Intellispec Control Enclosure and User Interface

This section contains an overview of the components in the control enclosure and user interface.

Intellispec User Interface

This is the user interface, which includes the monitor, keyboard, and login device (optional).

Your system may have a monitor attached to the control cabinet, or attached to a pole, as shown below.

Your system has user interface hardware to operate the system. For logging into the system, your system may have the optional 1) biometric fingerprint reader or 2) RFID card reader.

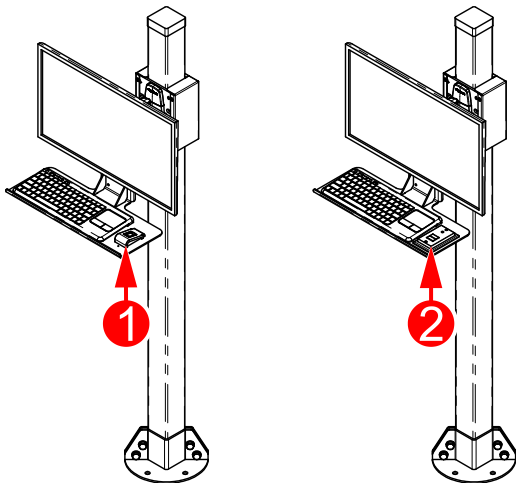

Intellispec Vision Processor

This is the vision processor (with computer) for the Intellispec Series 6S systems.

*Note: If you have a **wash-down version** of the cabinet, yours will have a cover over the gland plate (the side of the cabinet with P1 and E1 connectors).*

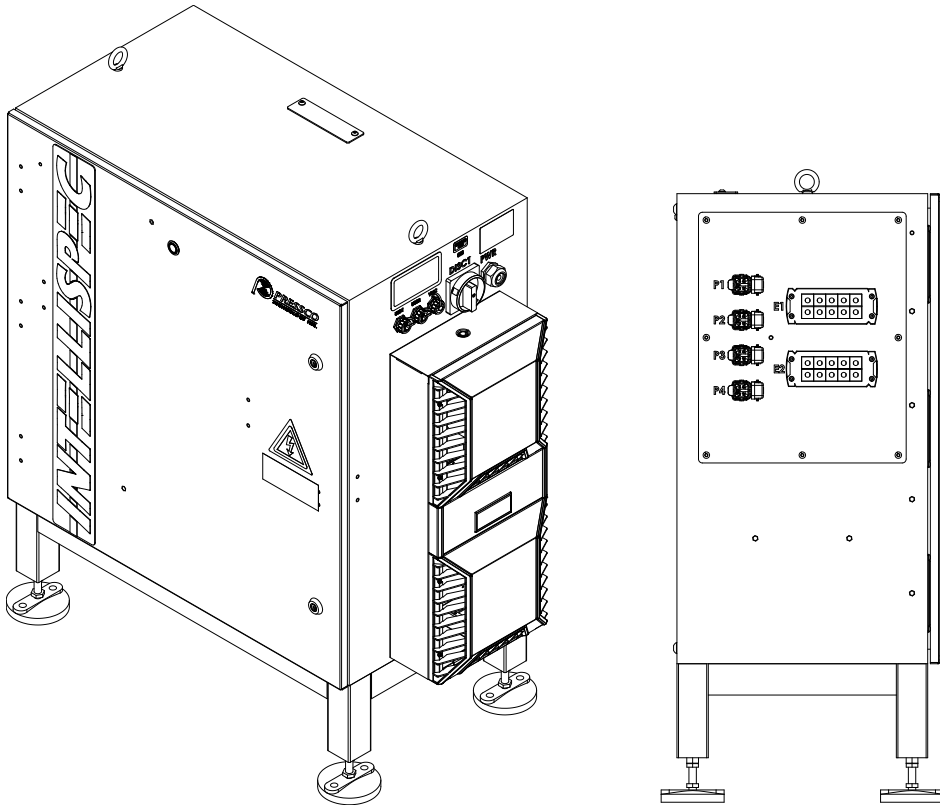

Specifications/ Notes

- Some connectors on the outside of the cabinet may be capped
- The computer in this cabinet CANNOT be swapped with a computer from another type of Intellispec cabinet. It is a different computer configuration.

5-Light Tree (Optional)

The lights on the optional light tree will turn on, off, or blink depending on status of certain hardware. Each lane has its own light tree.

Note: the light tree on your system may look different than the picture shown

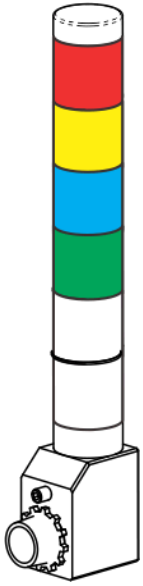
5-Light Tree	Light color	Condition	What it means
	Red	On - steady	Alarm condition
	Red	On - blinking	Part tracker board lost communication with the host PC or has an error and needs to initiate an alarm
	Red	Off	No alarm (OK)
	Amber	On - steady	Warning alarm condition
	Amber	Off	No warning (OK)
	Amber	0.5 second flash	System automatically resets Asynchronous Correlation FIFO (not used in all systems)
	Blue	On	Not assigned
	Blue	Off	Not assigned
	Green	On - steady	Lane is online
	Green	Off	Lane is offline
	White	On - steady	Power On (Part tracker board has power)
	White	Off	Power Off (Part tracker board has no power)

Power On and Off at the Control Enclosure

Power on: Turn on the switch DISC 1 [item 1]. The power indicator [2] will illuminate. The software will start automatically. (You must log in and put the system online to begin inspection)

Note: it takes about a minute for the computer to start after the main power switch is turned ON

Power off: Turn off the switch. The system, including the computer, shuts down. The UPS shuts down.

⚠ WARNING - When you shut down power using this switch, there is still voltage present on the UPS inside the unit until it discharges.

! Important - If you want to restart the system, turn off the power, let the software and components completely shut down, and leave the power off for about one minute before turning it back on. This allows the electronic components to correctly reset.

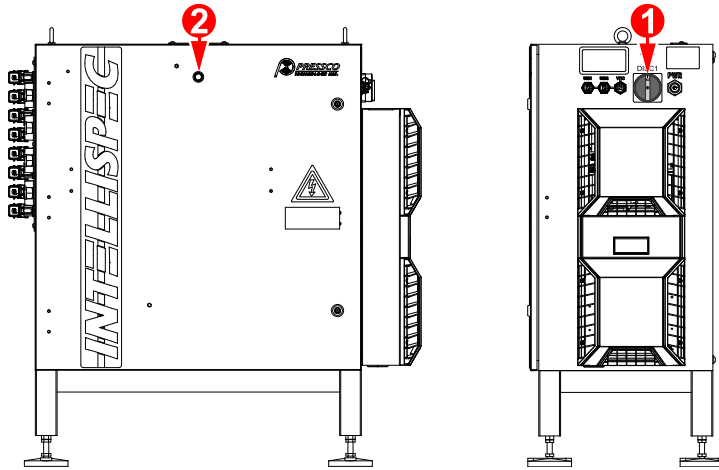

USB Ports Intellispec Cabinet

There are two USB ports on the side of the cabinet.

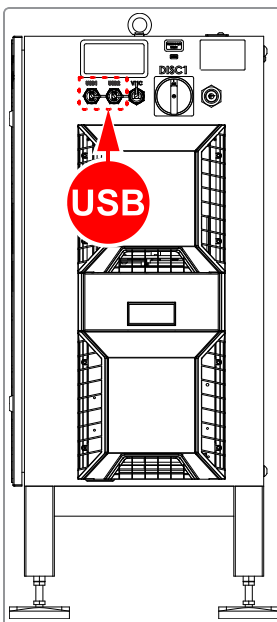

⊘ The USB ports are not for charging your phone! Only use these ports to import or export data.

Use the USB ports when you are:

- Importing or Exporting Part Programs from another system
- Exporting user accounts
- Importing user accounts
- Creating a Support Package
- Saving images, especially to send with a support package

Biometric Login Device

The Biometric Identification login device is used to log in and out of the Pressco system. This device is optional and must be purchased with the system.



To log in with this device, press your finger to the device. The following are conditions for use:

- You must use the same finger as initially set up by your administrator
- If you do not know how your account was set up (or which finger you used), contact your administrator
- If, after three tries, the Pressco does not recognize your finger print, you must log in using the On Screen Keyboard (OSK)

Access the Internal Components with the Power Off

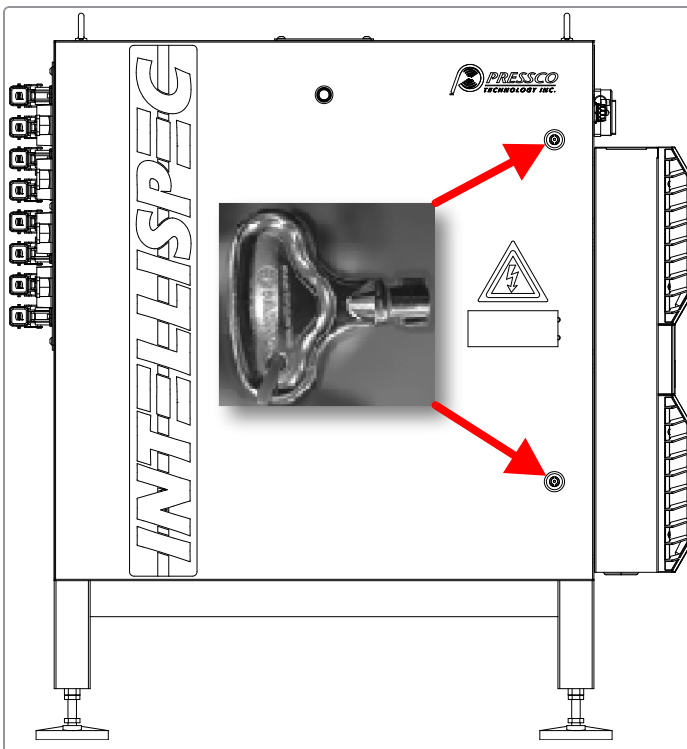

To access the components inside of the control cabinet, you will need the keys (supplied by Pressco).

⚠ WARNING - When the system is powered down, there is still voltage present at the UPS. Only **AUTHORIZED PERSONNEL** should attempt to open the system. We recommend that only **AUTHORIZED PERSONNEL** have access to the keys.

Chapter 7 Components and Wiring Diagrams

This section provides a list of components in the control enclosure, as well as wiring diagrams.

External Connections

Note: If you have a wash-down version of the cabinet, yours will have a cover over the gland plate (the side of the cabinet with P1 and E1 connectors).

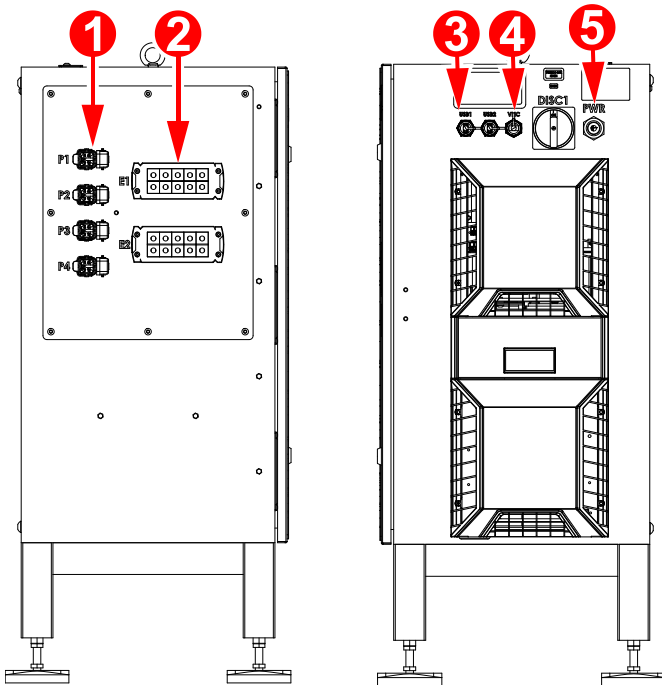

- 1) P1 - P4 connectors - 60 VDC out to inspection modules
- 2) E block connectors - inspection module connections
- 3) USB1 and USB2 - for data transfer
- 4) VNC - Ethernet connector
- 5) P1 or PWR - Incoming power (Note: your cabinet may be labeled with P1 or PWR)

Included Components

The components in the diagram are installed in your system.

Note: Your system will be configured for your application. You may have more or fewer components than this illustration.

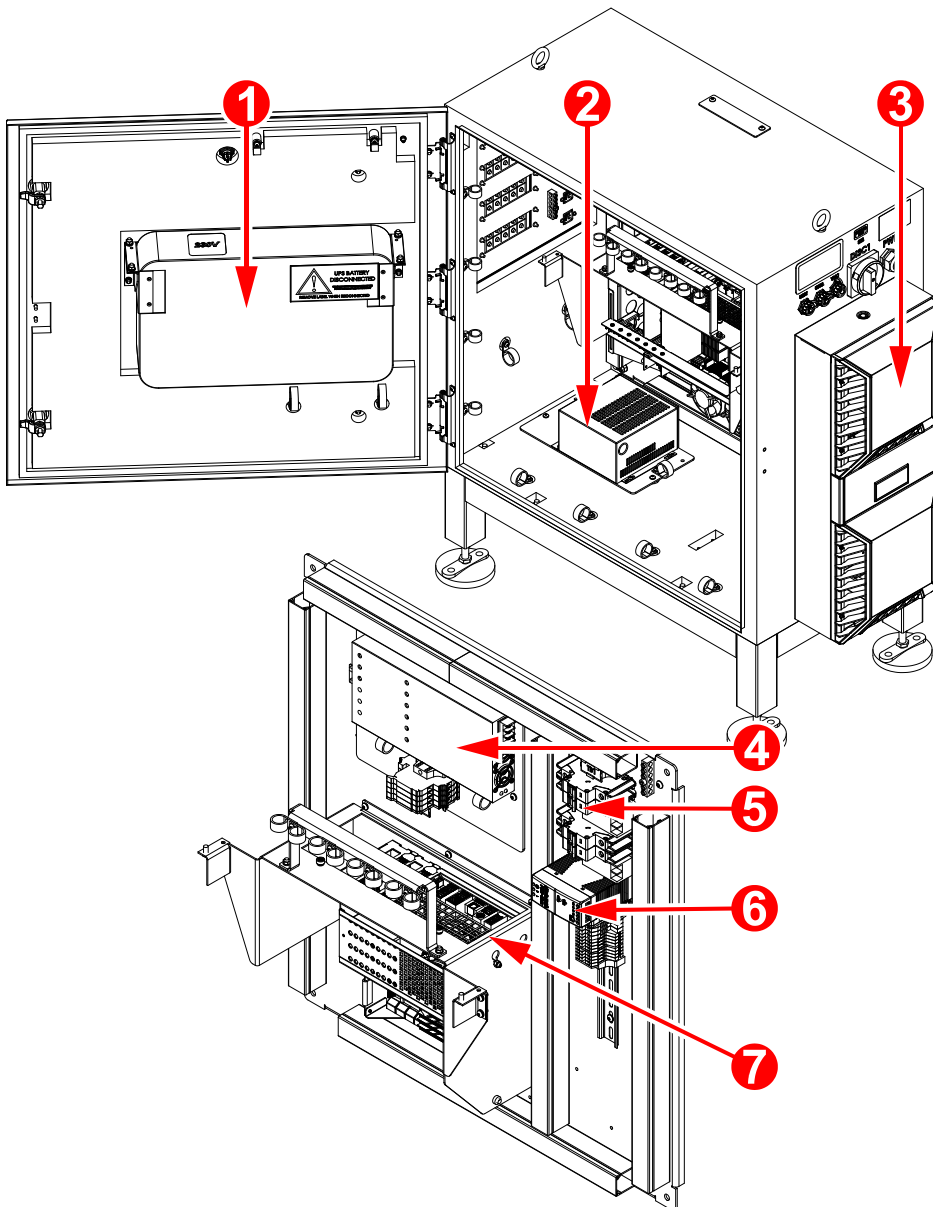

1) UPS 1500VA Rack Mount 900W

- for 120V models: Part number 81717
- for 230V models: Part number 81718

2) SUB-ASSY FRU POWER SUPPLY DS360 S6 (part number 85143).

3) Air Conditioner:

- **Standard cabinets:**
 - for 120V models: 670W 120V 50/60HZ (part number 85022)
 - for 230V models: 670W 230V 50/60H (part number 85023)
- **Wash-down cabinets:**

Chapter 7

- for 120V models: STAINLESS STEEL 670W 120V 50/60HZ (part number 85227)
- for 230V models: STAINLESS STEEL 670W 230V 50/60HZ (part number 85228)

4) SUB-ASSEMBLY DC POWER S6R+ (part number 85600) - See also "[Fuse Replacement](#)" below

- POWER SUPPLY 60VDC 1000W 85-264VAC 47-440HZ (part number 76029)
- ASSY TB2 60VDC POWER S6R+ (part number 85995)

5) Assembly TB1

- for 120V models: 120VAC S6 MIP(part number 85313)
- for 230V models: 230VAC S6 MIP (part number 85314)

6) Switch Ethernet managed programmed 10C/10C/12RUI (part number 79743)

7) Vision Processor Computer KIT FRU INTELLISPEC S6810 WIN10 M.2 S6-R2+ 10Gbps (Part number 85965)

Fuse Replacement

The fuses are located in **Terminal Block TB2**, which is located on the back panel inside the control enclosure.



WARNING - For continued protection against fire hazard, replace fuses only with the same type and ratings. The use of other fuses or materials is prohibited.



WARNING - Disconnect the product from the mains supply before replacing the fuse(s).

For fuse rating, refer to the table below.

Pressco part number	Fuse Number	Value
75517	FU1 - FU4	FUSE 5A 125V 5X20MM TIME DELAY

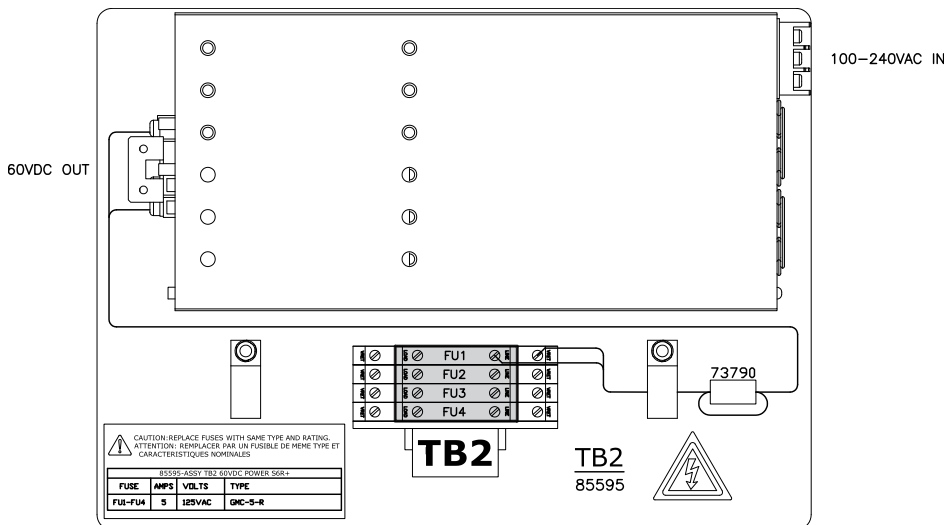

Wiring Diagram - Sub-Assembly DC Power

This is the wiring diagram for the DC Power supply to terminal block TB2. Drawing number 85600W.

DOC.
VERSION
01

DOCUMENT NO.
85600W

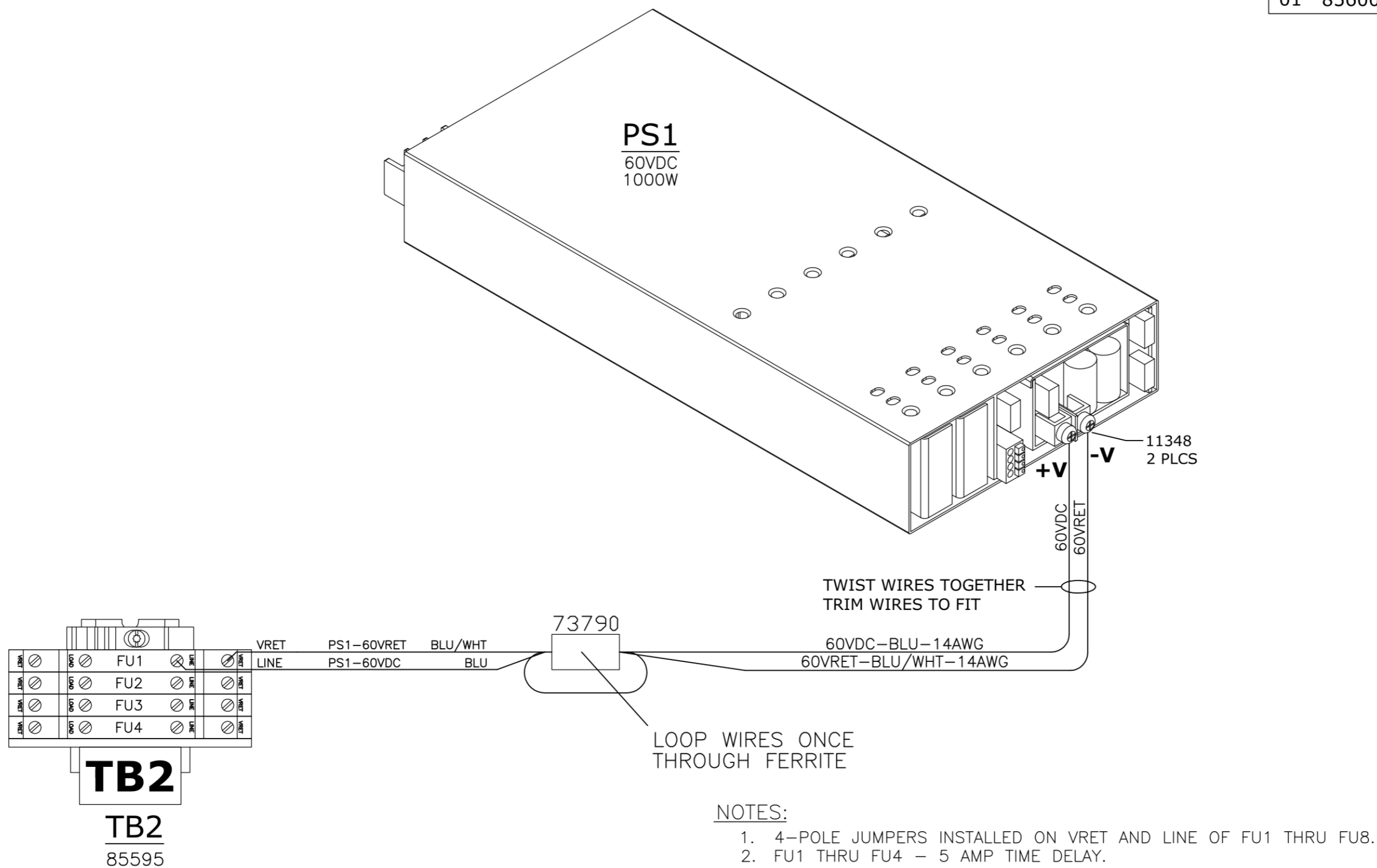

Wiring Diagrams - Standard Cabinet

The following pages contain the wiring diagrams F2305W for the Intellispec S6810 system.

Look at your serial number label to verify which drawing number applies to your system. The drawing number ends in "W."

Model: ASSY CABINET TYPE

System Number: XXXXX

Volts~: XXXV

Enclosure Type: 12

Phase: 1 Hertz: 60

Year of Construction: 20XX

Inspection System (FLA): X

Short Circuit Current Rating (kA): X

Air Conditioner (FLA): X

Electrical Diagram Wiring Index: ____W

Weight: XXXlbs/XXXkg

PRESSCO
Technology, Inc

29200 Aurora Road
Solon, Ohio 44139
440-498-2600
www.pressco.com

Made in USA

115VAC POWER DISTRIBUTION
SEE PAGES 3 AND 4 FOR 230VAC

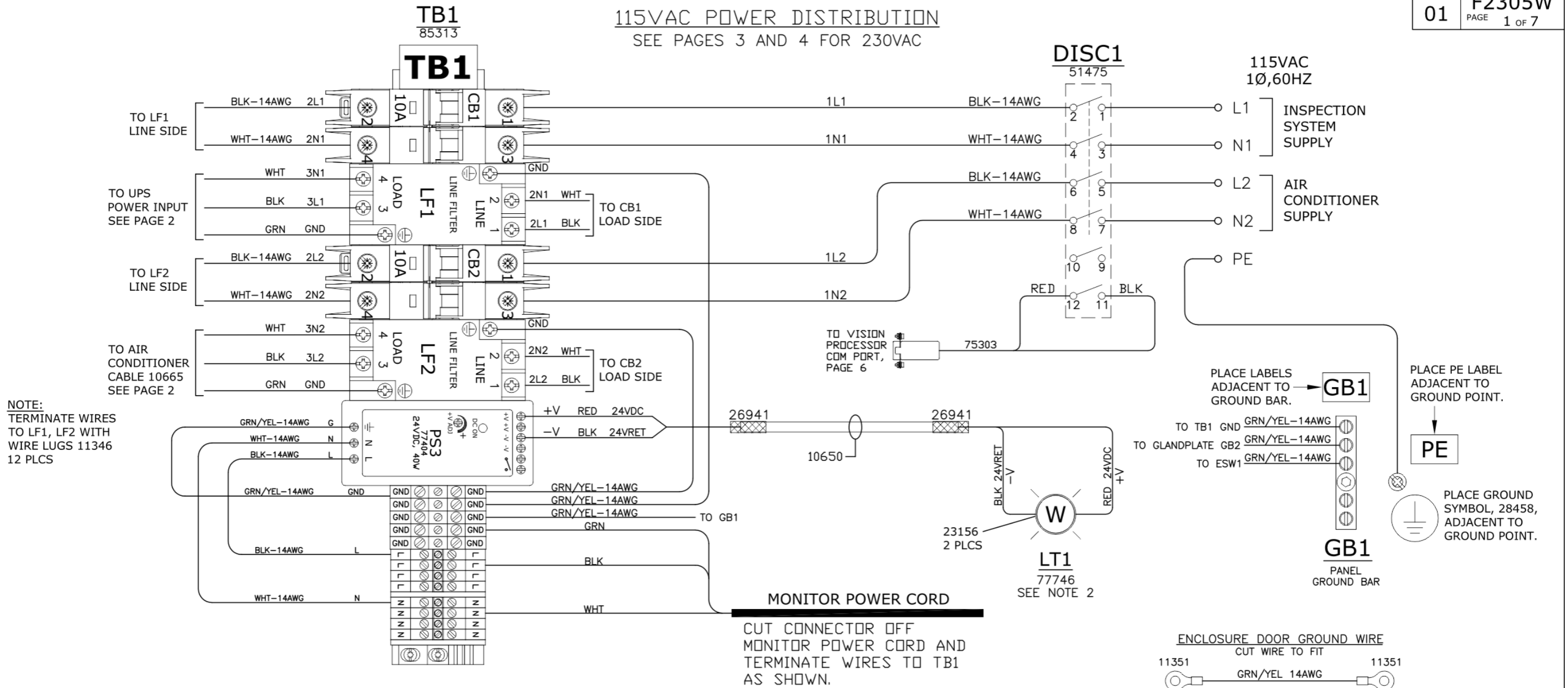

NOTE:
TERMINATE WIRES
TO LF1, LF2 WITH
WIRE LUGS 11346
12 PLCS

LABEL INFO-ITEM 53

Model Number: ASSY VP W/AC ISPEC S6810

System Number: XXXXX Volts~: 115
 Enclosure Type (IP/NEMA): 65/12 Phase: 1 Hertz: 60
 Year of Construction: XXXX Inspection System (FLA): 8
 Short Circuit Current Rating (kA): 5 Air Conditioner (FLA): 6
 Electrical Diagram Wiring Index: F2305W

PRESSCO 29200 Aurora Road
 Technology, Inc Solon, Ohio 44139
 440-498-2600
 www.pressco.com Made in USA

SEE 120V P/N:
85577

NOTES:

- 1) SEE PROJECT ENGINEER FOR SYSTEM NUMBER.
- 2) PLACE LABEL 'LT1' BELOW LIGHT ON INSIDE OF DOOR.

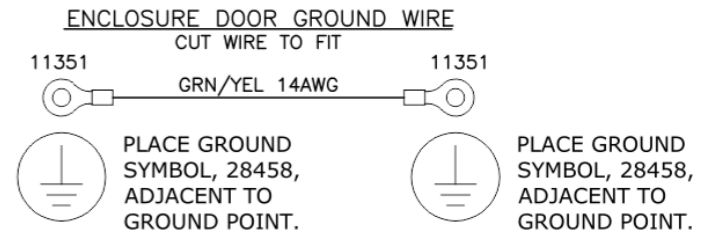

MONITOR POWER CORD
CUT CONNECTOR OFF
MONITOR POWER CORD AND
TERMINATE WIRES TO TB1
AS SHOWN.

115VAC POWER DISTRIBUTION
SEE PAGES 3 AND 4 FOR 230VAC

UPS1

81717
115VAC
1,500VA/900W
60Hz

ESW1 GROUND

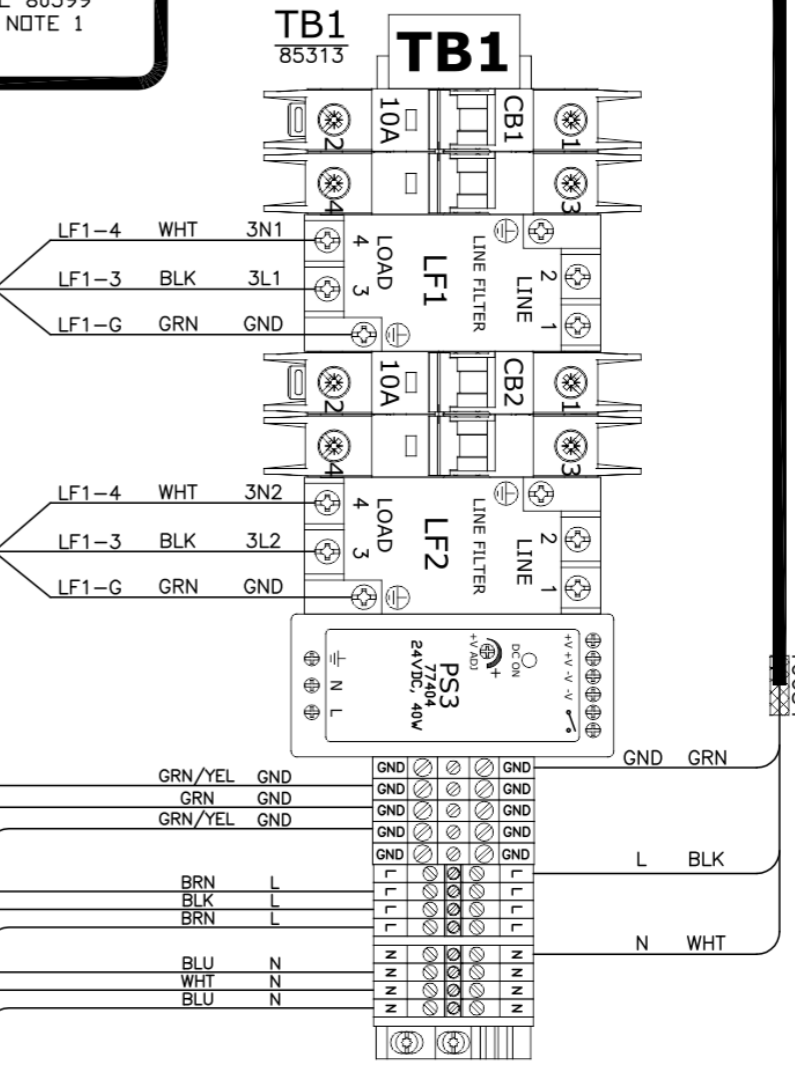
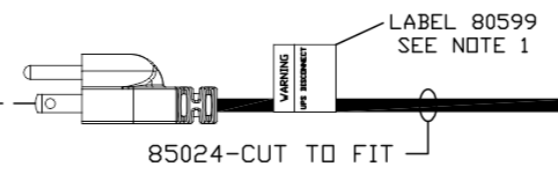
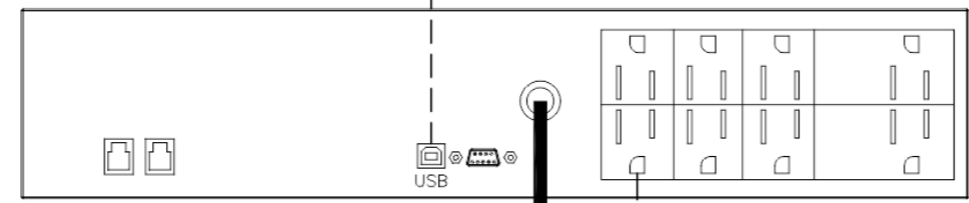
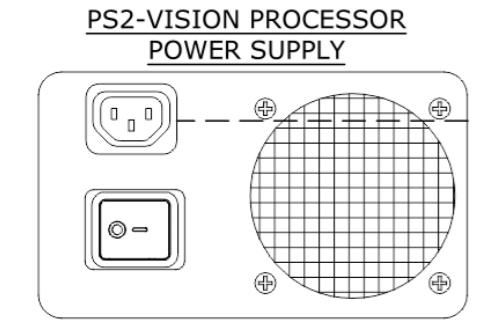
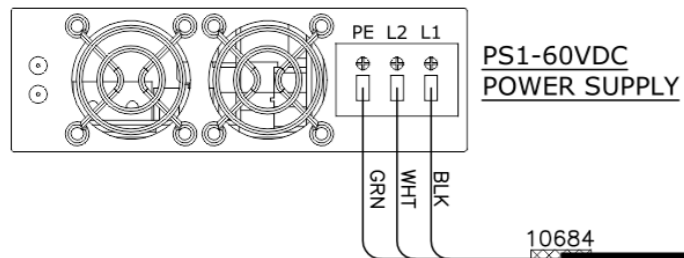
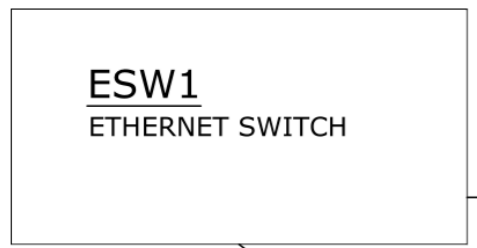
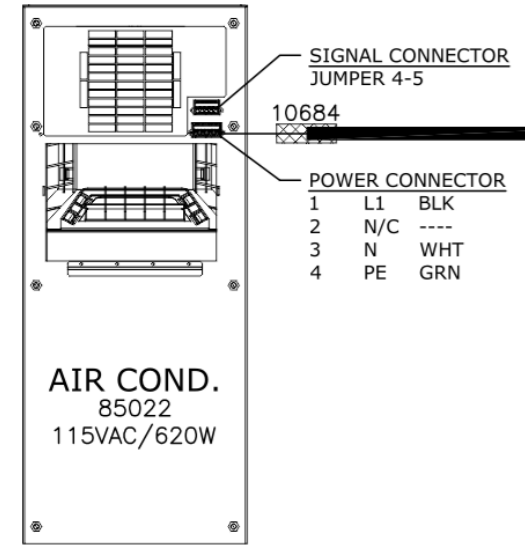
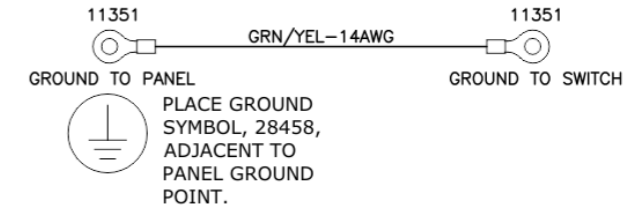

NOTES:
1) FOLD LABEL 80599 IN HALF AROUND UPS OUTPUT CABLE. ENSURE TEXT SIDE IS VISIBLE.

230VAC POWER DISTRIBUTION
SEE PAGES 1 AND 2 FOR 115VAC

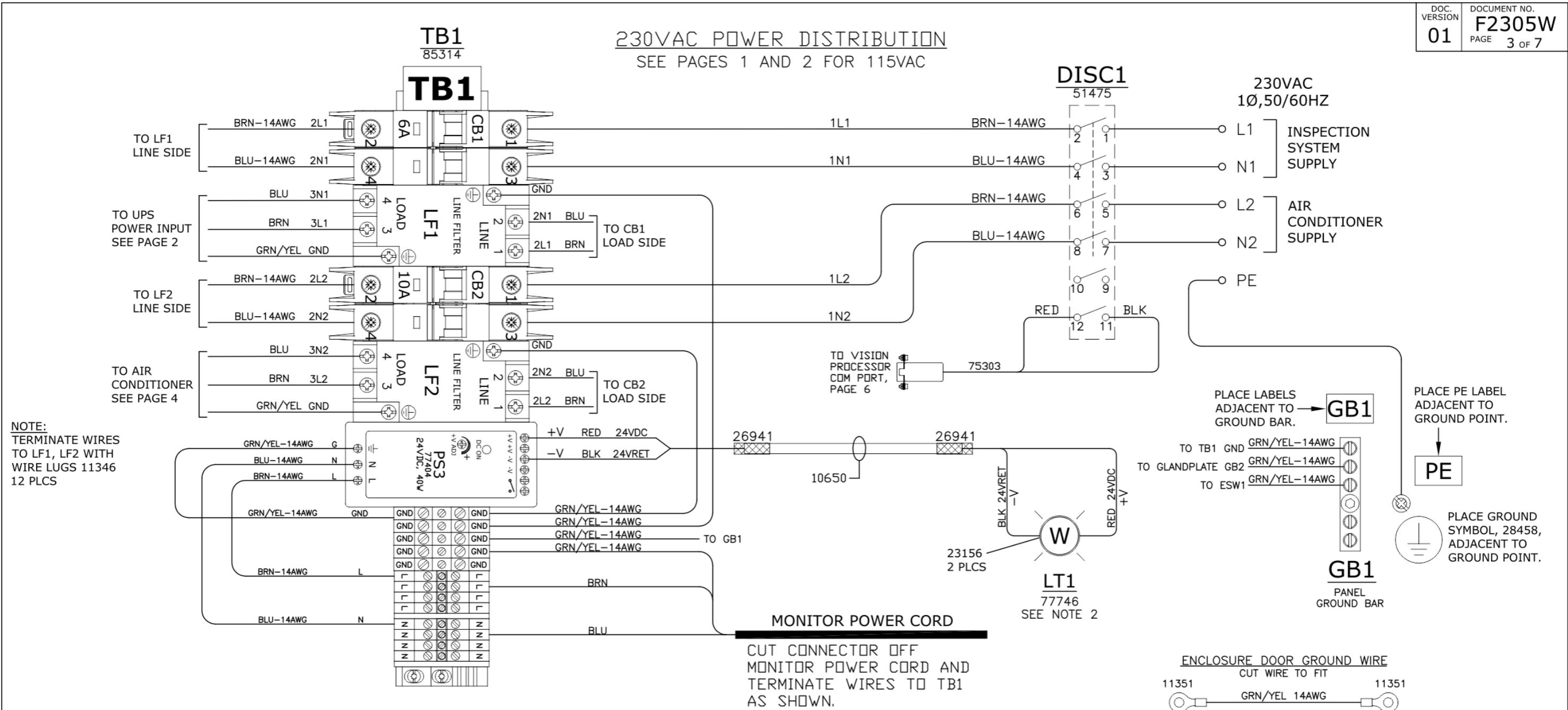

LABEL INFO-ITEM 53

Model Number: ASSY VP W/AC ISPEC S6810

System Number: XXXXX Volts~: 230
 Enclosure Type (IP/NEMA): 65/12 Phase: 1 Hertz: 50/60
 Year of Construction: XXXX Inspection System (FLA): 4
 Short Circuit Current Rating (kA): 5 Air Conditioner (FLA): 2.7
 Electrical Diagram Wiring Index: F2305W

PRESSCO Technology, Inc
 29200 Aurora Road
 Solon, Ohio 44139
 440-498-2600
 www.pressco.com

CE
Made in USA

SEE 230V P/N:
85578

- NOTES:**
- 1) SEE PROJECT ENGINEER FOR SYSTEM NUMBER.
 - 2) PLACE LABEL 'LT1' BELOW LIGHT ON INSIDE OF DOOR.

230VAC POWER DISTRIBUTION
SEE PAGES 1 AND 2 FOR 115VAC

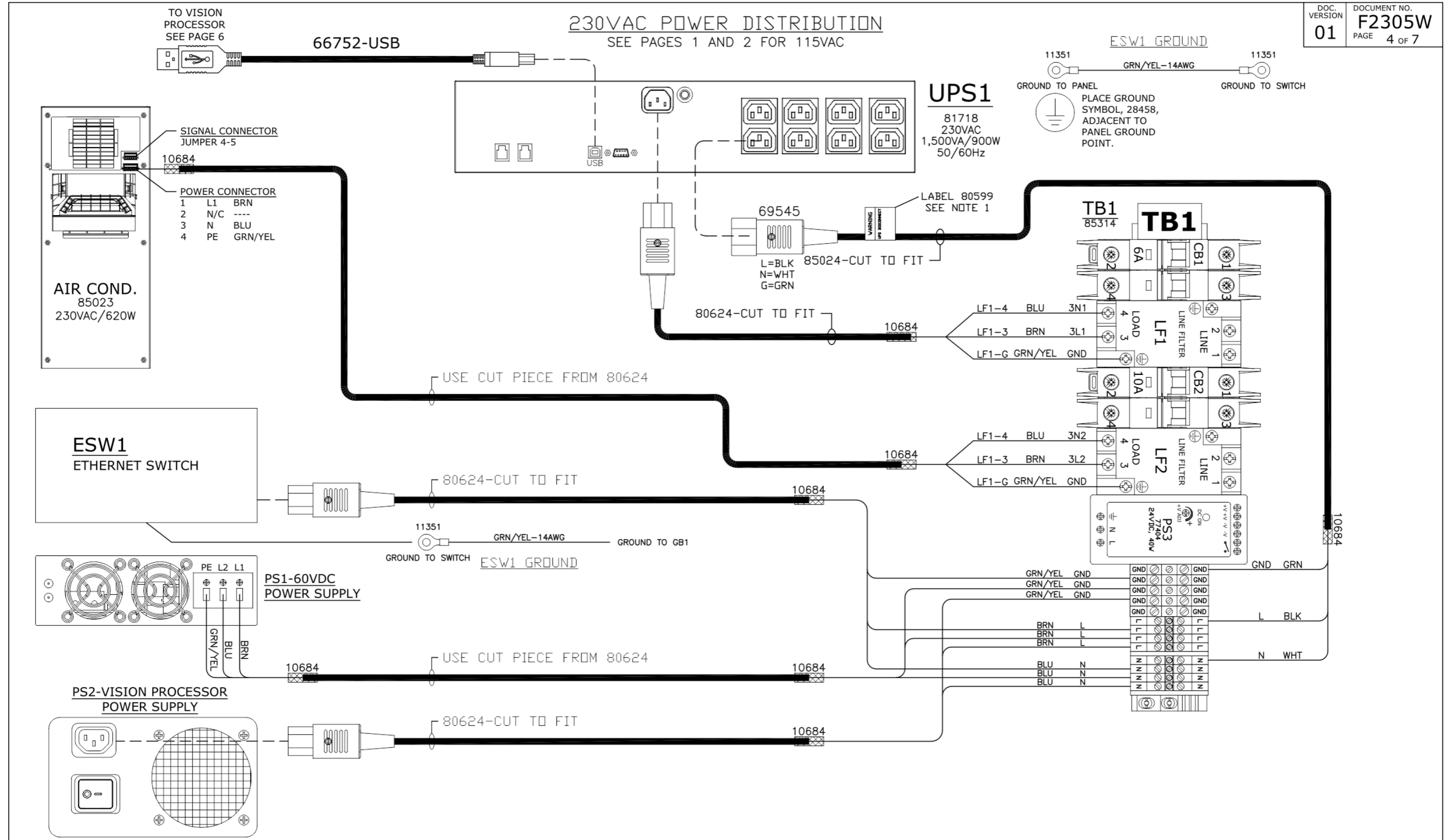

TO VISION PROCESSOR
SEE PAGE 6

66752-USB

SIGNAL CONNECTOR JUMPER 4-5

10684

POWER CONNECTOR

1	L1	BRN
2	N/C	----
3	N	BLU
4	PE	GRN/YEL

UPS1

81718
230VAC
1,500VA/900W
50/60Hz

ESW1 GROUND

11351 GRN/YEL-14AWG 11351

GROUND TO PANEL GROUND TO SWITCH

PLACE GROUND SYMBOL, 28458, ADJACENT TO PANEL GROUND POINT.

AIR COND.
85023
230VAC/620W

ESW1
ETHERNET SWITCH

PS1-60VDC
POWER SUPPLY

PS2-VISION PROCESSOR
POWER SUPPLY

PS3
77404
24VDC, 40W

NOTES:

1) FOLD LABEL 80599 IN HALF AROUND UPS OUTPUT CABLE. ENSURE TEXT SIDE IS VISIBLE.

DC POWER DISTRIBUTION

FUSE NO.	RATING	TYPE
FU1-FU4	125VAC/5A 5MM X 20MM	BK/GMC-5-R

FUSE BLOCK NOTES:

- 4-POLE JUMPERS INSTALLED ON VRET AND LINE OF FU3 THRU FU6.
- REPLACE FUSE WITH SAME TYPE AND RATING.

GLANDPLATE CONNECTORS

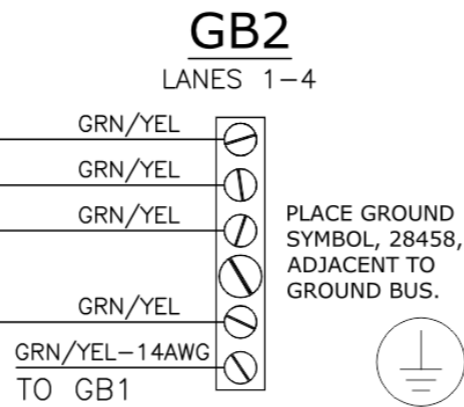
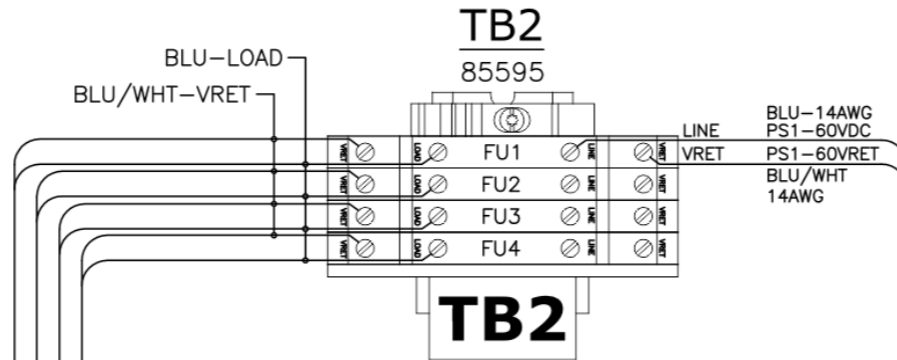
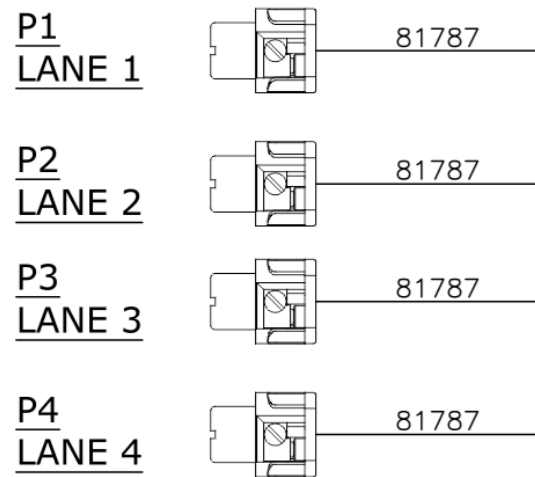

GROUND BAR GB2

GB2 INSTALLED ON CONNECTOR GLANDPLATE.

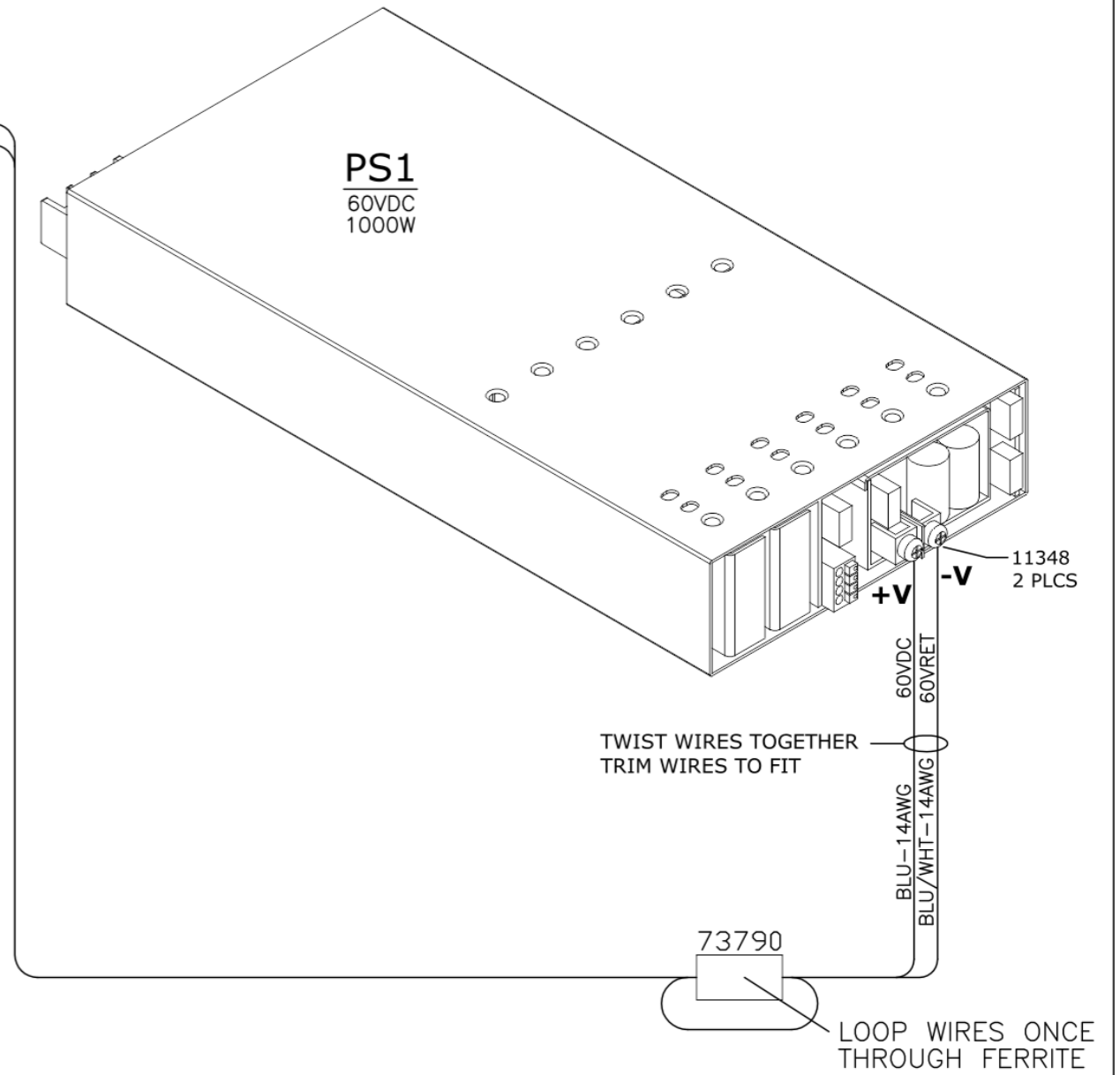

CABLE ROUTING CONFIGURATION

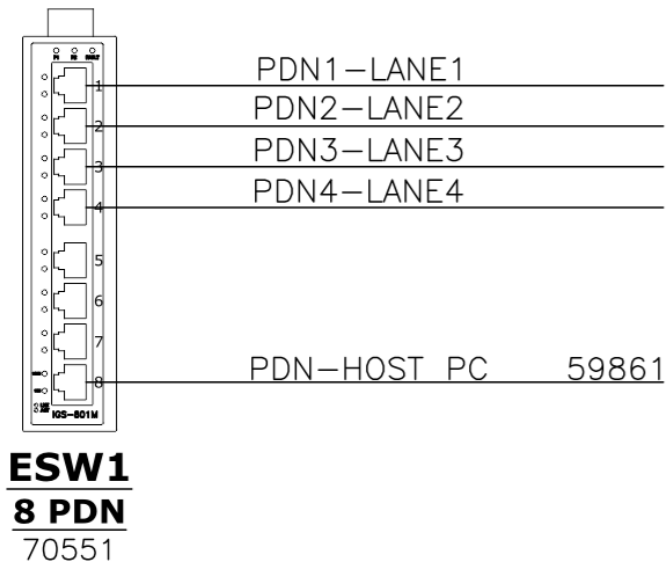

E1

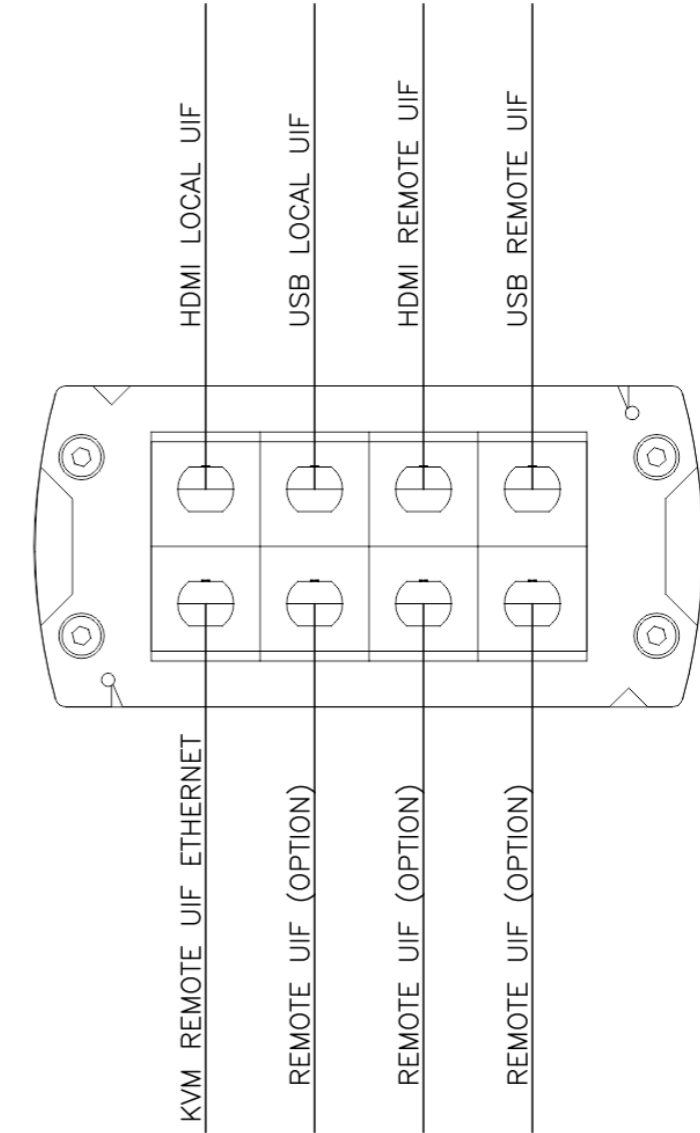
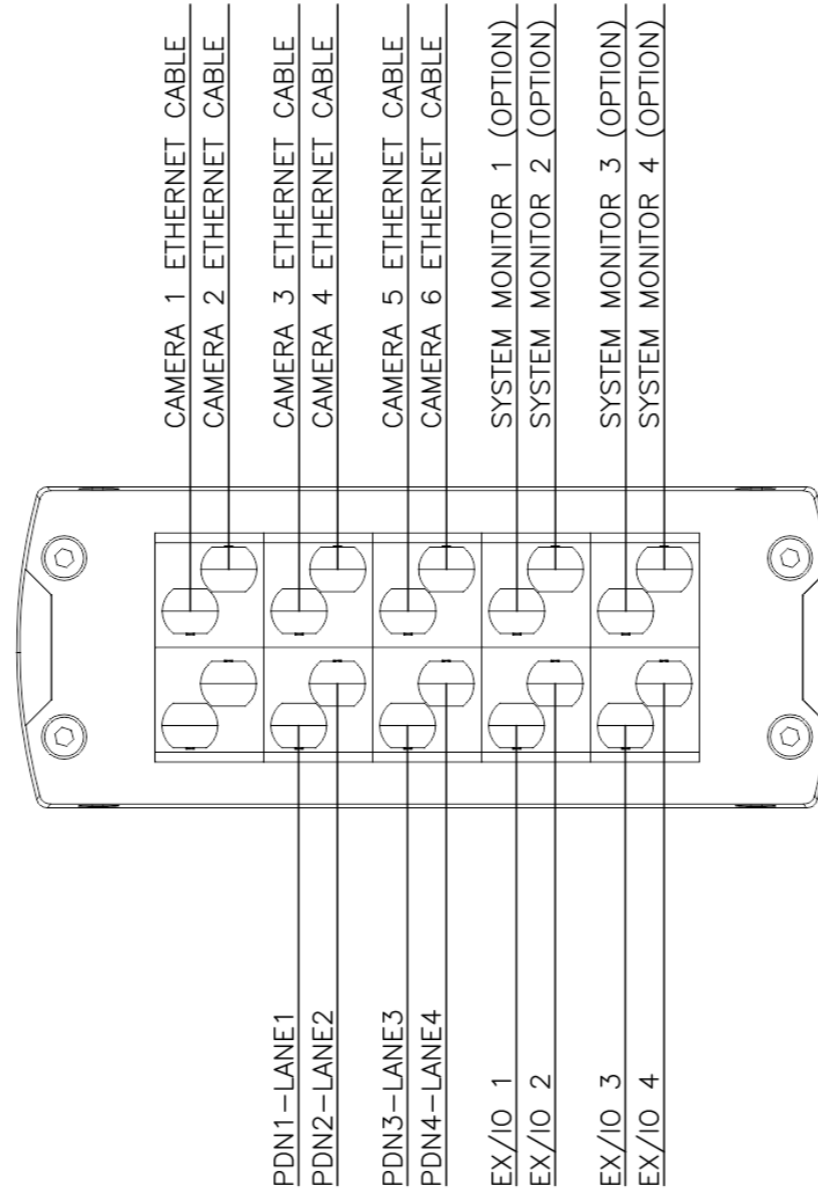

E2

NOTE:
INSTALL FERRITE 73790 AT
GLAND PLATE END ON ALL
ETHERNET CABLES ROUTED
THRU GLAND PLATE.

VISION PROCESSOR WITH 52 PORT ETHERNET SWITCH 79743

SEE PAGE 6 FOR 28 PORT ETHERNET SWITCH

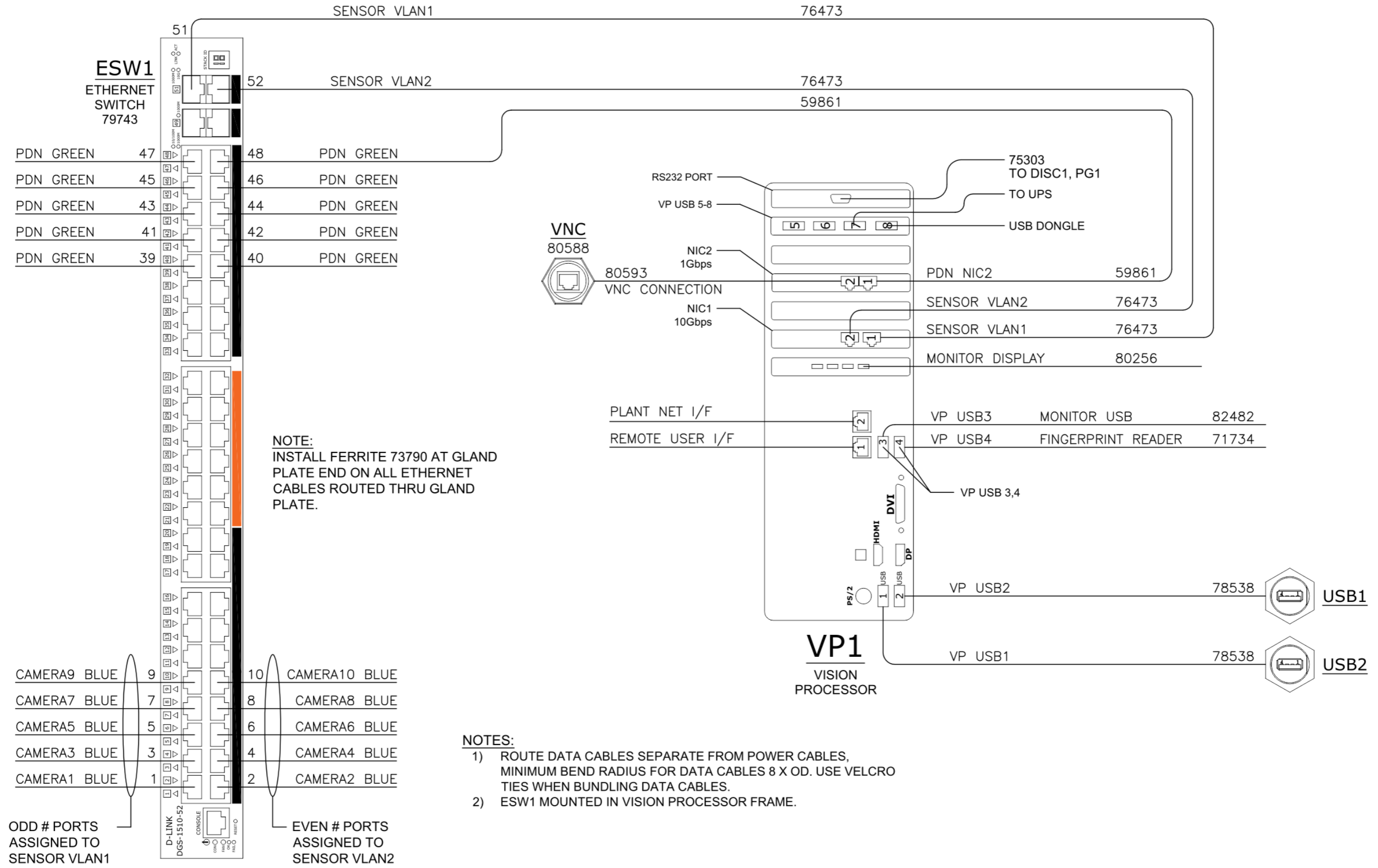

- NOTES:**
- 1) ROUTE DATA CABLES SEPARATE FROM POWER CABLES, MINIMUM BEND RADIUS FOR DATA CABLES 8 X OD. USE VELCRO TIES WHEN BUNDLING DATA CABLES.
 - 2) ESW1 MOUNTED IN VISION PROCESSOR FRAME.

Wiring Diagrams - Wash-Down Cabinet

The following pages contain the wiring diagrams F2306W for the Intellispec S6810 system with a wash-down cabinet.

Look at your serial number label to verify which drawing number applies to your system. The drawing number ends in "W."

Model: ASSY CABINET TYPE

System Number: XXXXX

Volts~: XXXV

Enclosure Type: 12

Phase: 1 Hertz: 60

Year of Construction: 20XX

Inspection System (FLA): X

Short Circuit Current Rating (kA): X

Air Conditioner (FLA): X

Electrical Diagram Wiring Index: ____W

Weight: XXXlbs/XXXkg

PRESSCO
Technology, Inc

29200 Aurora Road
Solon, Ohio 44139
440-498-2600
www.pressco.com

Made in USA

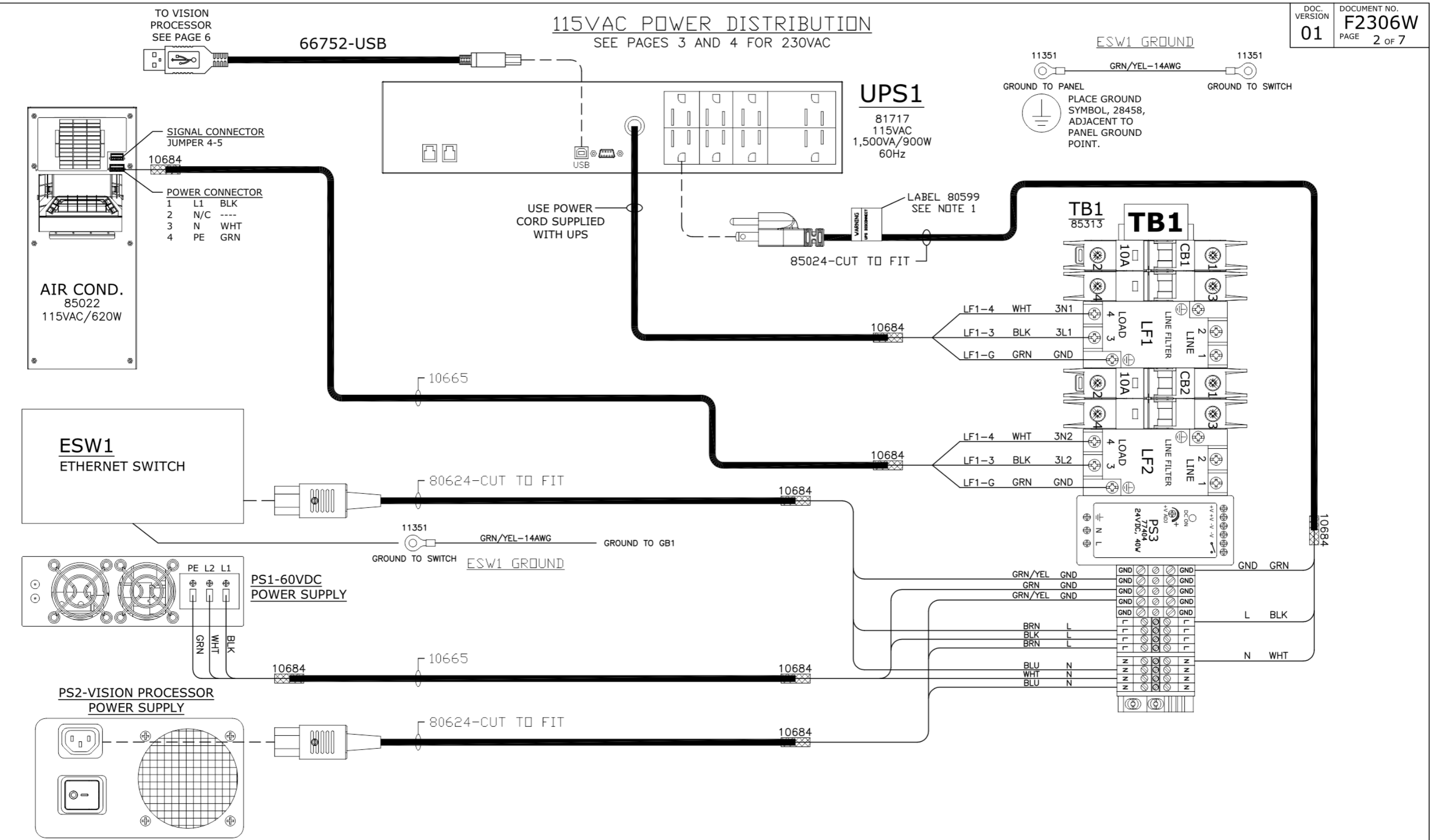

NOTES:

1) FOLD LABEL 80599 IN HALF AROUND UPS OUTPUT CABLE. ENSURE TEXT SIDE IS VISIBLE.

230VAC POWER DISTRIBUTION
SEE PAGES 1 AND 2 FOR 115VAC

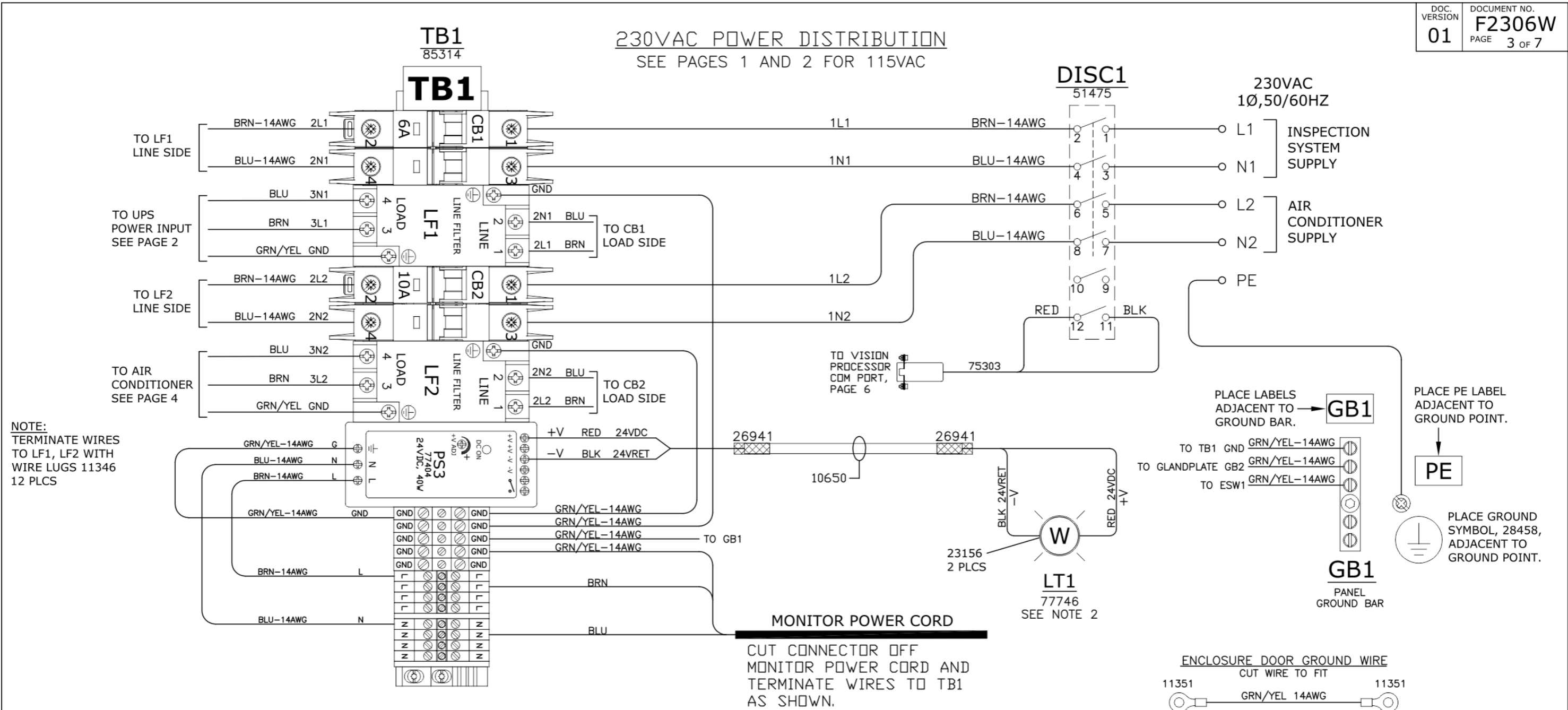

LABEL INFO-ITEM 53

Model Number: ASSY VP W/AC ISPEC WD S6810

System Number: XXXXX Volts~: 230
 Enclosure Type (IP/NEMA): 65/12 Phase: 1 Hertz: 50/60
 Year of Construction: XXXX Inspection System (FLA): 4
 Short Circuit Current Rating (kA): 5 Air Conditioner (FLA): 2.7
 Electrical Diagram Wiring Index: F2306W

PRESSCO Technology, Inc 29200 Aurora Road Solon, Ohio 44139 440-498-2600 www.pressco.com

CE Made in USA

SEE 230V P/N:
85580

- NOTES:
- 1) SEE PROJECT ENGINEER FOR SYSTEM NUMBER.
 - 2) PLACE LABEL 'LT1' BELOW LIGHT ON INSIDE OF DOOR.

230VAC POWER DISTRIBUTION
SEE PAGES 1 AND 2 FOR 115VAC

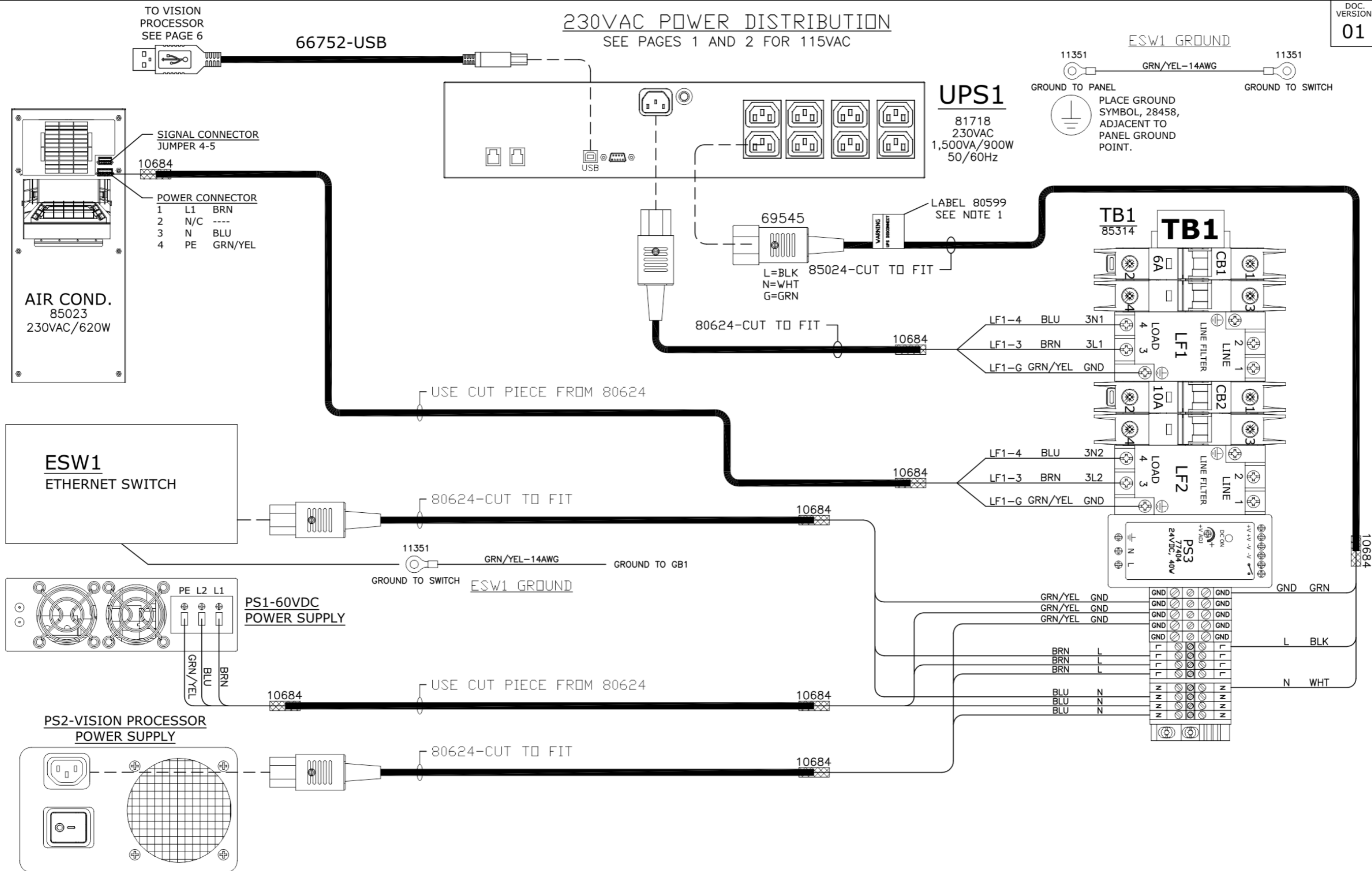

NOTES:

1) FOLD LABEL 80599 IN HALF AROUND UPS OUTPUT CABLE. ENSURE TEXT SIDE IS VISIBLE.

DC POWER DISTRIBUTION

FUSE NO.	RATING	TYPE
FU1-FU4	125VAC/5A 5MM X 20MM	BK/GMC-5-R

FUSE BLOCK NOTES:

1. 4-POLE JUMPERS INSTALLED ON VRET AND LINE OF FU3 THRU FU6.
2. REPLACE FUSE WITH SAME TYPE AND RATING.

GLANDPLATE CONNECTORS

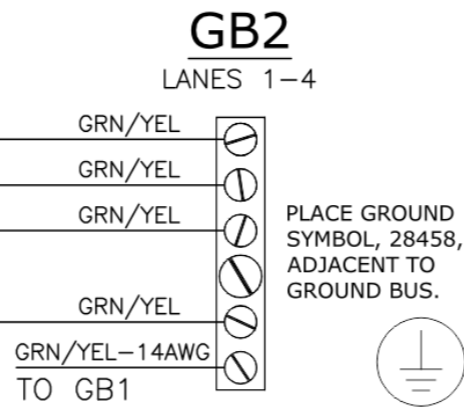
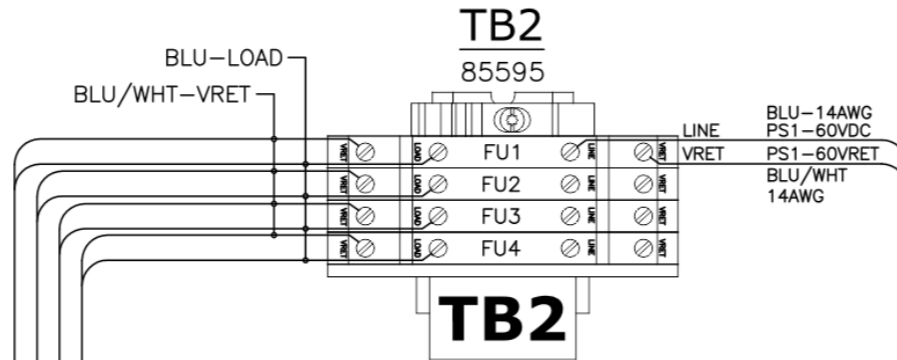
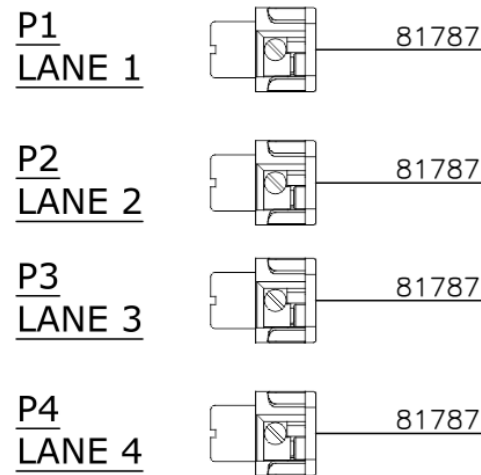

GROUND BAR GB2
GB2 INSTALLED ON CONNECTOR GLANDPLATE.

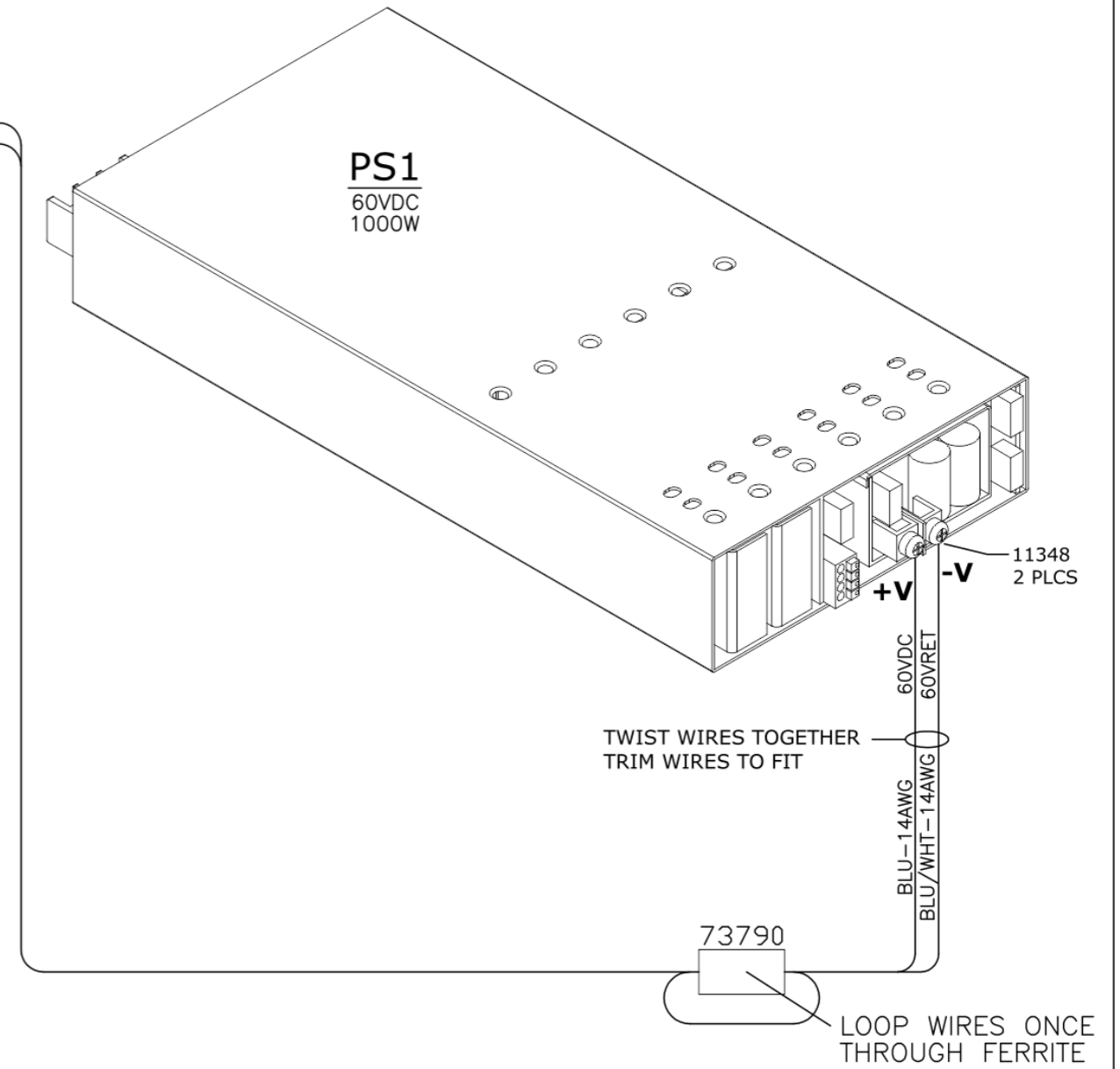

CABLE ROUTING CONFIGURATION

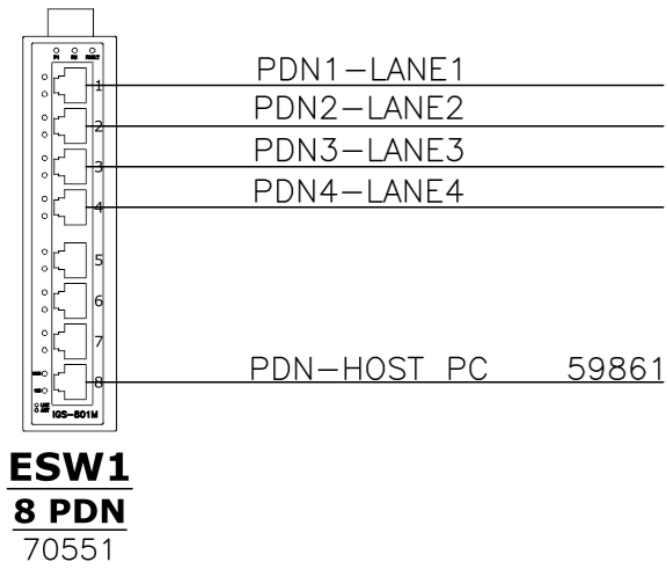

E1

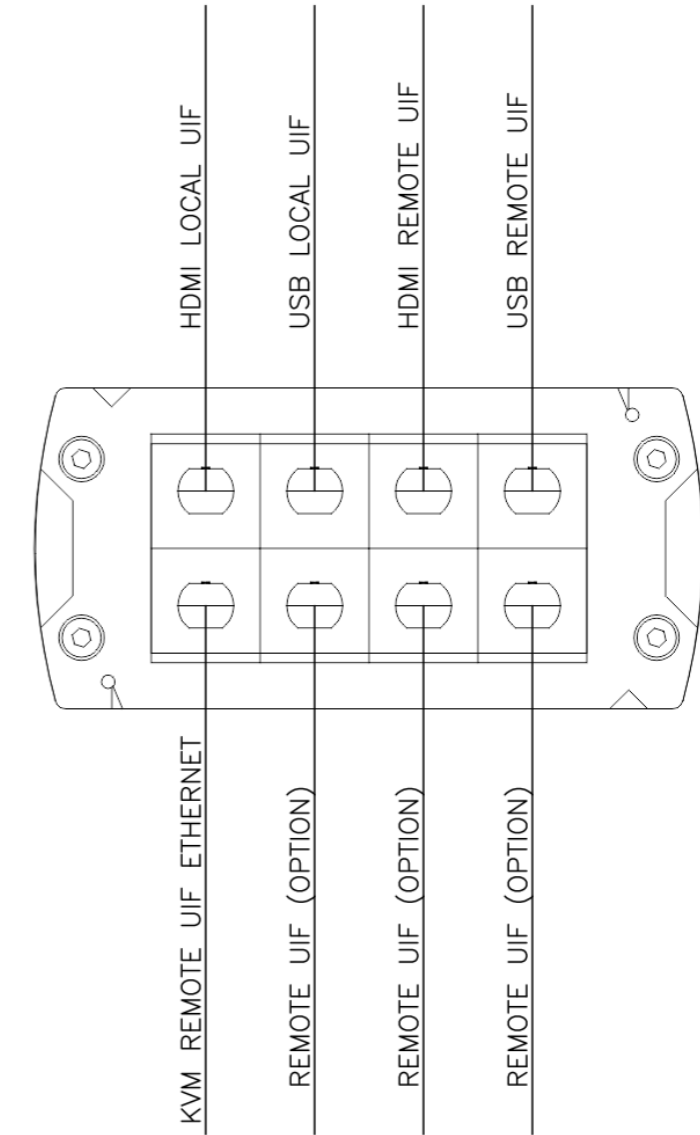
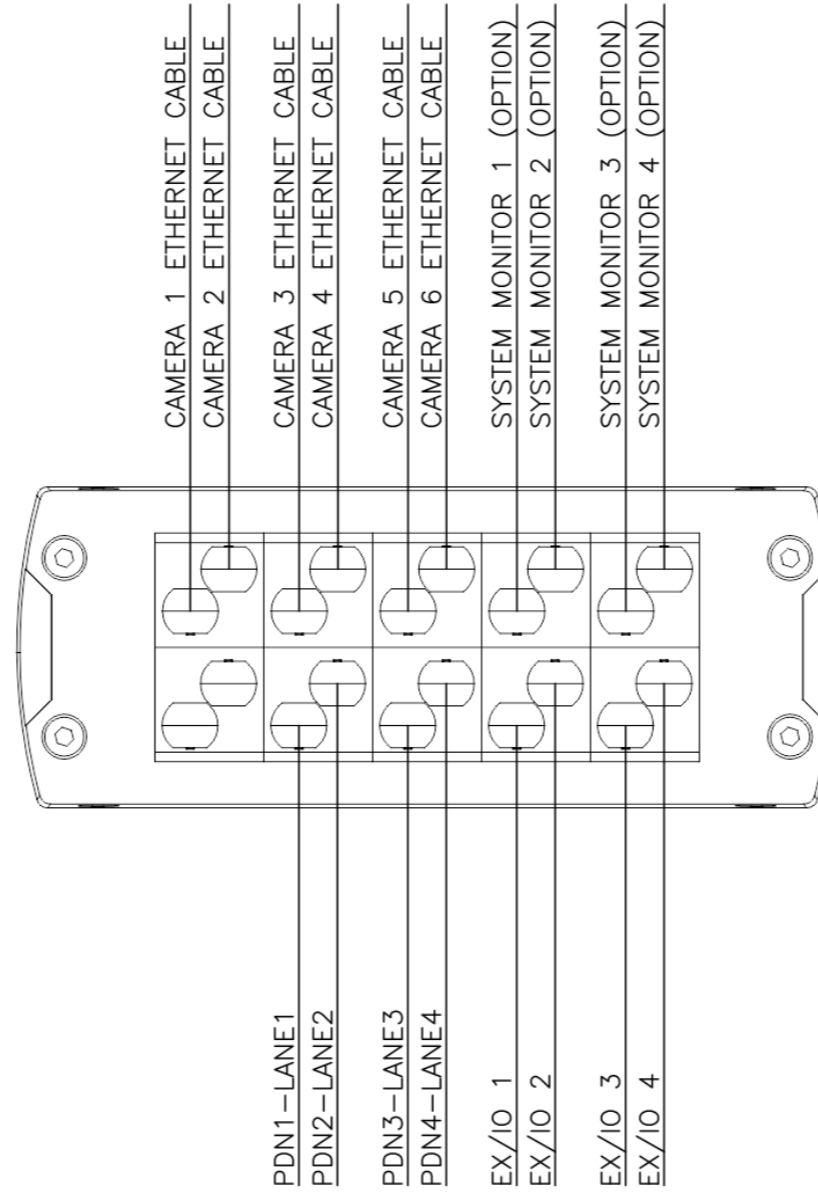

E2

NOTE:
INSTALL FERRITE 73790 AT
GLAND PLATE END ON ALL
ETHERNET CABLES ROUTED
THRU GLAND PLATE.

VISION PROCESSOR WITH 52 PORT ETHERNET SWITCH 79743

SEE PAGE 6 FOR 28 PORT ETHERNET SWITCH

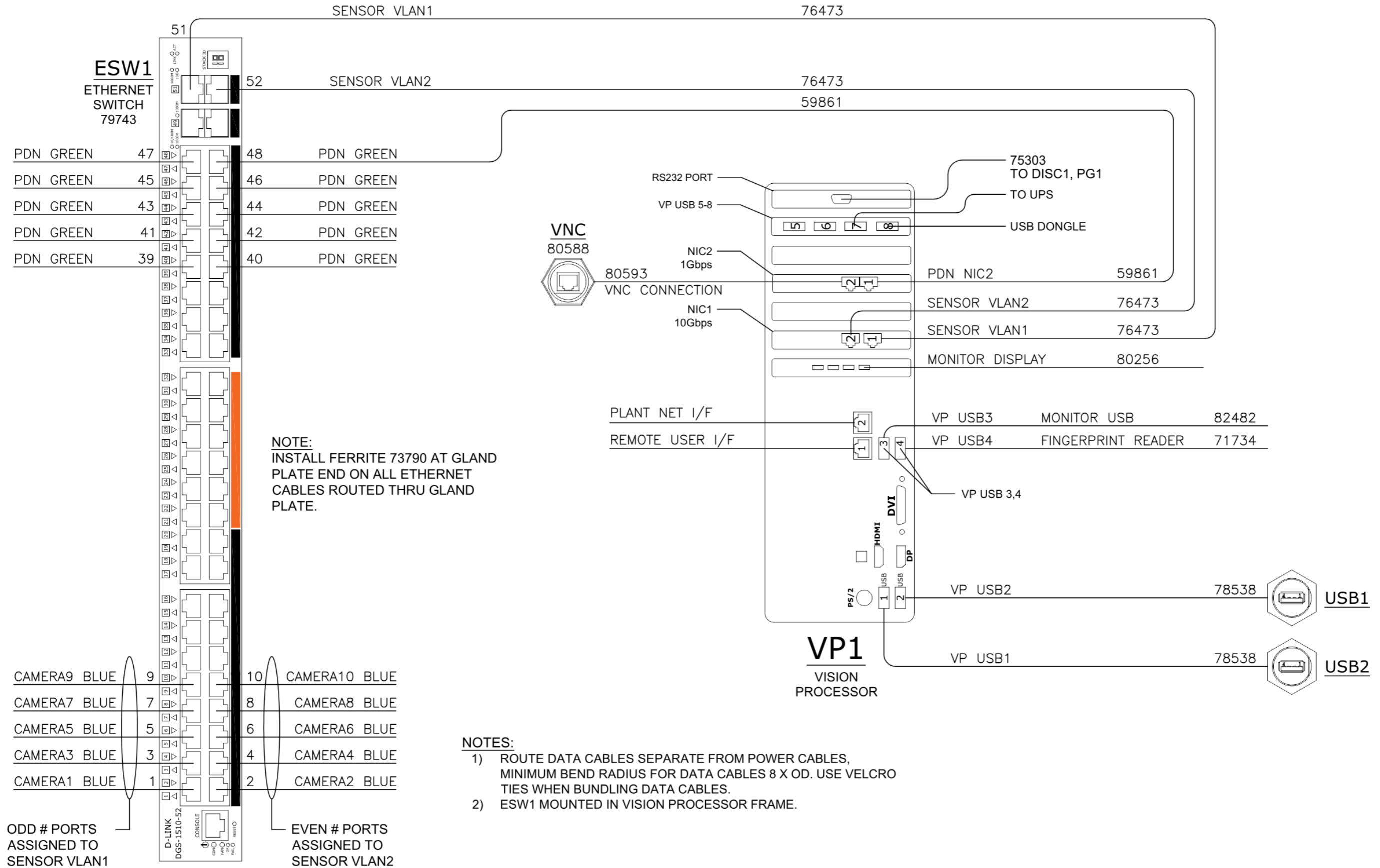

Chapter 8 Troubleshooting

This section contains some basic troubleshooting tips to use if the system is not working properly.

Reboot the Intellispec System

You may need to reboot the system if power or communication has been lost between the Vision Processor and the inspection modules.

Symptoms may include that the inspection module light has stopped flashing, and the system is no longer taking pictures.

Note: if the power to the Vision Processor UPS is interrupted for more than two minutes, the software will automatically shut itself down and then shut down the Vision Processor PC. The software will restart. You will just need to log in and put the system back online.

Restart the system

If your system has stopped communicating, or the software has stopped operating, we recommend that you restart the whole system. This will reset the software, the inspection module, and all the communication devices of the system.

To restart the system:

1. Turn off the main power switch on the control cabinet (DISC 1). The system will shut down, including a controlled shut down of the software.
2. Wait until the software and all the components have shut down, and then wait for about 40 more seconds to allow the electronic components to reset.
3. Turn on the main power switch (DISC 1). The system will start, and the Intellispec software will load. Log in to begin using the system.

Note: The system restart takes several minutes to complete.

If the system restart does not fix the problem, try one of the solutions below, or contact Pressco. "[Copyright Notice / Contact Us](#)" on page 2

Restart the Software Application

You may need to restart the software if you see a software error that, for some reason, may not have been cleared by restarting the entire system.



You must have proper user permissions to exit the software. This prevents unauthorized system shutdowns. Contact your system administrator if you need user permissions.

Important - When restarting the software, it is important to choose the correct option from the Shut Down System menu. Only select Shut Down Intellispec and Restart Computer as described below.

To restart the Intellispec software:

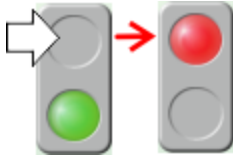
1. Log in.
2. Take the system offline. (Repeat for all lanes if necessary)



3.  Exit the software: Home | Tools | Shut Down Intellispec and Restart Computer.
4.  Click the OK button. The Intellispec software and computer shuts down and restarts. Your system may be configured to go online at startup. Otherwise, the software will come up in System Overview mode where you can log in to continue operating the system.

Reboot the computer

If restarting the software application does not clear the errors, or the software does not restart, or you see the "System in Transition" message, try rebooting the computer.

To reboot the computer:

1. Press Ctrl + Alt + Delete on the keyboard.
2. Use the Log Off option to log off of Intellispec.
3. At the Windows Login Prompt, enter "pvpass" as the password for the Intellispec user account. Once login is complete the application software will be launched.

Note: The system reboot takes several minutes to complete.

Chapter 9 Extended I-O S6

This section contains information about the optional Extended I/O board in Intellispec Series 6 systems.

Note: In some systems, such as FHCP inspection systems, the Extended I/O board is always included (not optional).

Extended I-O Board S6

This optional module provides additional input and output ports for communicating with the Intellispec Series 6 system. The board may be installed within a cluster box or within an inspection module. The board is connected to the lane's Part Tracker board via a ribbon cable.

Note: Each Extended I/O board handles only one lane.

Note: Extended I/O is not available with an Embedded Cluster Box.

Some signals must be enabled in the software through the "Extended I-O Configuration" on page 66.

Below is the layout for the Extended I/O board. "Extended I-O Signals S6" on the next page

Switch SW1 selects Intellispec 24V power supply or User 24V power supply. "Extended I-O Switch SW1 Selection" on page 64

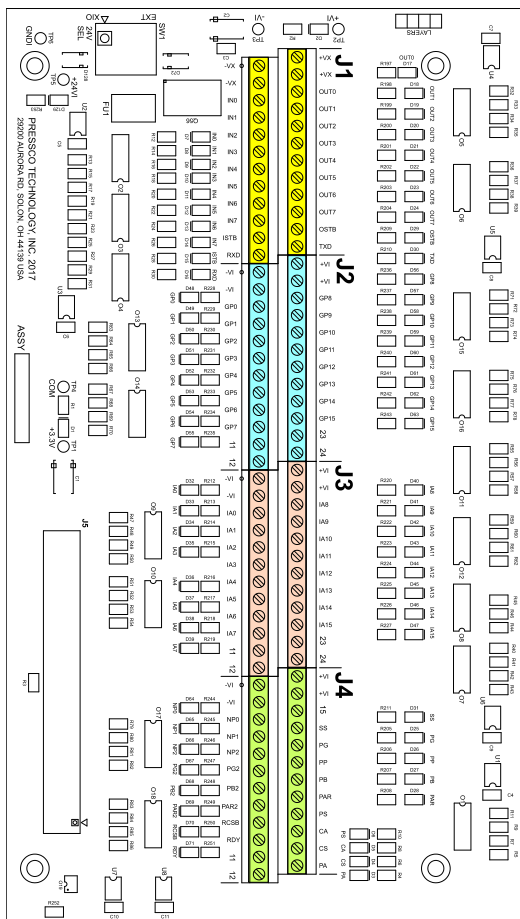

Extended I-O Signals S6

Switch SW1 selects Intellispec 24V power supply or User 24V power supply.

Labels used on the board: Series 6

Signal	Label	Signal	Label
User +24VDC	+VX	System State	SS
User 24VRET	-VX	Part Present	PP
+24VDC	+VI	Part Good	PG
24VRET	-VI	Part Bad	PB
Generic Input n	INn	Part at Reject	PAR
Generic Output n	Outn	Part Good 2	PG2
Input Strobe	ISTB	Part Bad 2	PB2
Output Strobe	OSTB	Part at Reject 2	PAR2
Group n	GPn	Print Statistics	PS
Inspection Alarm n	IAn	Clear Alarms	CA
Not Processed n	NPn	Clear Statistics	CS
Reject Confirm Sensor Blocked	RCSB	Preform Alarm	PA
RS232 Transmit	TXD	System Ready	RDY
RS232 Receive	RXD		

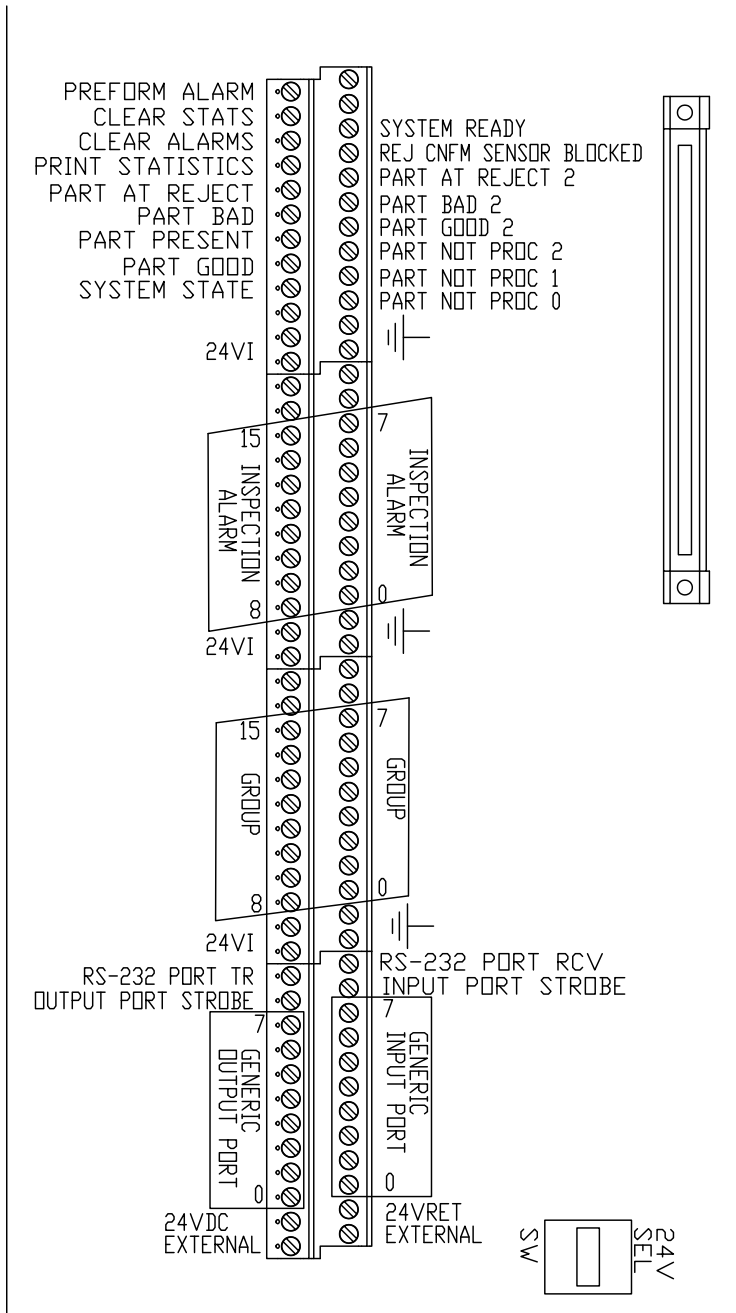

Note: some signals are not currently used

All Extended I/O inputs are PNP. Outputs are selectable to be either open collector or open emitter. However, that selection applies to ALL output signals.

The input and power LEDs are visual indicators. The maximum current output is 50mA. See also information about Extended I/O circuits.

Terminal	Signal and Indicator LED label	Input (I) or Output (O)	Comments
J1-1	User 24VRET (-VX)		
J1-2	User 24VRET (-VX)		

Terminal	Signal and Indicator LED label	Input (I) or Output (O)	Comments
J1-3	Generic Input 0 (IN0)	I	
J1-4	Generic Input 1 (IN1)	I	Port 0 and Port 1 used in Remote Part Program Switching
J1-5	Generic Input 2 (IN2)	I	
J1-6	Generic Input 3 (IN3)	I	Generic Input bits may be used for Auto-Learn or Alternate Part Processing
J1-7	Generic Input 4 (IN4)	I	
J1-8	Generic Input 5 (IN5)	I	
J1-9	Generic Input 6 (IN6)	I	
J1-10	Generic Input 7 (IN7)	I	
J1-11	Input Strobe (ISTB)	I	
J1-12	RS232 RX (RXD)	I	
J1-13	User +24VDC (+VX)		
J1-14	User +24VDC (+VX)		
J1-15	Generic Output 0 (OUT0)	O	
J1-16	Generic Output 1 (OUT1)	O	
J1-17	Generic Output 2 (OUT2)	O	
J1-18	Generic Output 3 (OUT3)	O	
J1-19	Generic Output 4 (OUT4)	O	
J1-20	Generic Output 5 (OUT5)	O	
J1-21	Generic Output 6 (OUT6)	O	
J1-22	Generic Output 7 (OUT7)	O	
J1-23	Output Strobe (OSTB)	O	Pulsed When data of Generic Output Port (0-7) is set
J1-24	RS232 TX (TXD)	O	

Terminal	Signal and Indicator LED label	Input (I) or Output (O)	Comments
J2-1	24VRET (-VI)		
J2-2	24VRET (-VI)		
J2-3	Group 0 (GP0)	O	
J2-4	Group 1 (GP1)	O	
J2-5	Group 2 (GP2)	O	Pulses for 12 ms when an inspection fails in the user-defined group (online mode only)
J2-6	Group 3 (GP3)	O	
J2-7	Group 4 (GP4)	O	
J2-8	Group 5 (GP5)	O	Walk By Setup
J2-9	Group 6 (GP6)	O	
J2-10	Group 7 (GP7)	O	

Terminal	Signal and Indicator LED label	Input (I) or Output (O)	Comments
J2-11	no connection		
J2-12	no connection		
J2-13	+24VDC (+VI)		
J2-14	+24VDC (+VI)		
J2-15	Group 8 (GP8)	O	
J2-16	Group 9 (GP9)	O	
J2-17	Group 10 (GP10)	O	
J2-18	Group 11 (GP11)	O	See comments for Group 0 - 7 above
J2-19	Group 12 (GP12)	O	
J2-20	Group 13 (GP13)	O	
J2-21	Group 14 (GP14)	O	
J2-22	Group 15 (GP15)	O	
J2-23	no connection		
J2-24	no connection		

Terminal	Signal and Indicator LED label	Input (I) or Output (O)	Comments
J3-1	24VRET (-VI)		
J3-2	24VRET (-VI)		
J3-3	Inspection Alarm 0 (IA0)	O	Set when the associated alarm condition occurs and stays active until the alarm is cleared
J3-4	Inspection Alarm 1 (IA1)	O	
J3-5	Inspection Alarm 2 (IA2)	O	
J3-6	Inspection Alarm 3 (IA3)	O	
J3-7	Inspection Alarm 4 (IA4)	O	
J3-8	Inspection Alarm 5	O	Lane Alarm Configuration and Sensor Alarm Configuration

Terminal	Signal and Indicator LED label	Input (I) or Output (O)	Comments
	(IA5)		
J3-9	Inspection Alarm 6 (IA6)	O	
J3-10	Inspection Alarm 7 (IA7)	O	
J3-11	no connection		
J3-12	no connection		
J3-13	+24VDC (+VI)		
J3-14	+24VDC (+VI)		
J3-15	Inspection Alarm 8 (IA8)	O	
J3-16	Inspection Alarm 9 (IA9)	O	
J3-17	Inspection Alarm 10 (IA10)	O	
J3-18	Inspection Alarm 11 (IA11)	O	See comments for Inspection Alarm 0-7 above
J3-19	Inspection Alarm 12 (IA12)	O	
J3-20	Inspection Alarm 13 (IA13)	O	
J3-21	Inspection Alarm 14 (IA14)	O	
J3-22	Inspection Alarm 15 (IA15)	O	
J3-23	no con-		

Terminal	Signal and Indicator LED label	Input (I) or Output (O)	Comments
	no connection		
J3-24	no connection		

Terminal	Signal and Indicator LED label	Input (I) or Output (O)	Comments
J4-1	24VRET (-VI)		
J4-2	24VRET (-VI)		
J4-3	Not Processed 0 (NP0)	O	Pulses for 12 ms when a part is not processed due to a system malfunction (online mode only)
J4-4	Not Processed 1 (NP1)	O	
J4-5	Not Processed 2 (NP2)	O	
J4-6	Part Good 2 (PG2)	O	Group B outputs. See Extended I/O Configuration
J4-7	Part Bad 2 (PB2)	O	
J4-8	Part at Reject 2 (PAR2)	O	
J4-9	Reject Confirm Sensor Blocked (RCSB)	O	Reject confirm sensor signal pulse width exceeding programmed limit
J4-10	System Ready (RDY)	O	Steady state ON or OFF 24V. ON = lane is online, no critical alarms are triggered, and no lost communication. OFF = lane is offline, a critical alarm has been triggered, or communication is lost (example: part tracker communication lost).
J4-11	no connection		
J4-12	no connection		
J4-13	+24VDC (+VI)		
J4-14	+24VDC(+VI)		
J4-15	no connection		
J4-16	System State (SS)	O	Indicates whether the lane is online or offline.

Terminal	Signal and Indicator LED label	Input (I) or Output (O)	Comments
			Online = active. Offline = inactive.
J4-17	Part Good (PG)	O	Pulses for 12 ms for each part declared good by the inspection
J4-18	Part Present (PP)	O	Pulses for 12 ms when the part present sensor detects a part
J4-19	Part Bad (PB)	O	Pulses for 12 ms for each part declared bad by the inspection
J4-20	Part at Reject (PAR)	O	Pulses for 12 ms for each part that crosses the reject point (online mode only)
J4-21	Print Statistics (PS)	I	Prints the lane statistics to currently configured printer or file Schedule Reports
J4-22	Clear Alarms (CA)	I	Clears the lane alarms
J4-23	Clear Statistics (CS)	I	Clears the lane statistics
J4-24	Preform Alarm (PA)	I	Used only in special applications. Activated by the Preform Material Handling system.

Test Points

Function	Test Point
+3.3V	TP1
+3.3V Gnd	TP4
+24VDC (+VI)	TP2
24VRET (-VI)	TP3
+24VI	TP5
GNDI	TP6

Extended I-O Switch SW1 Selection

Switch SW1 – 24VDC Selection:

SW1 has three positions:

- XIO – In the XIO position 24VDC is supplied by the Intellispec power supply. 24VDC will be on terminals labeled +VI and 24VRET will be on terminals labeled –VI at J2, J3 and J4. Devices requiring 24VDC power should be connected to the +VI and –VI terminals. The terminals labeled +VX and –VX at J1 are not used. The 24VDC indicator LED D2 will be on if SW1 is in this position. There is no isolation from the Intellispec power supply. See Figure 1.
- CTR – In the center position there is no connection to a 24VDC source. There will be no voltage present at the terminals labeled +VI and –VI at J2, J3 and J4. The CTR position is not labeled on the PCB. The 24VDC indicator LED D2 will be off if SW1 is in this position. See Figure 2.
- EXT – In the EXT position 24VDC is supplied by an external 24VDC power supply. The external 24VDC must be connected to the +VX terminals and the external 24VRET must be connected to the –VX terminals. Devices requiring 24VDC power should be connected to the +VI and –VI terminals. The 24VDC indicator LED D2 will be on if SW1 is in this position. The external power supply and signals are isolated from the Intellispec power supply. See Figure 3.

Note: 24VDC LED D129 is on to indicate 24VDC is supplied through the ribbon cable from the part tracker board.



WARNING: Do not connect an external power supply to terminals labeled +VI or –VI.

Figure 1 - SW1 in the XIO Position

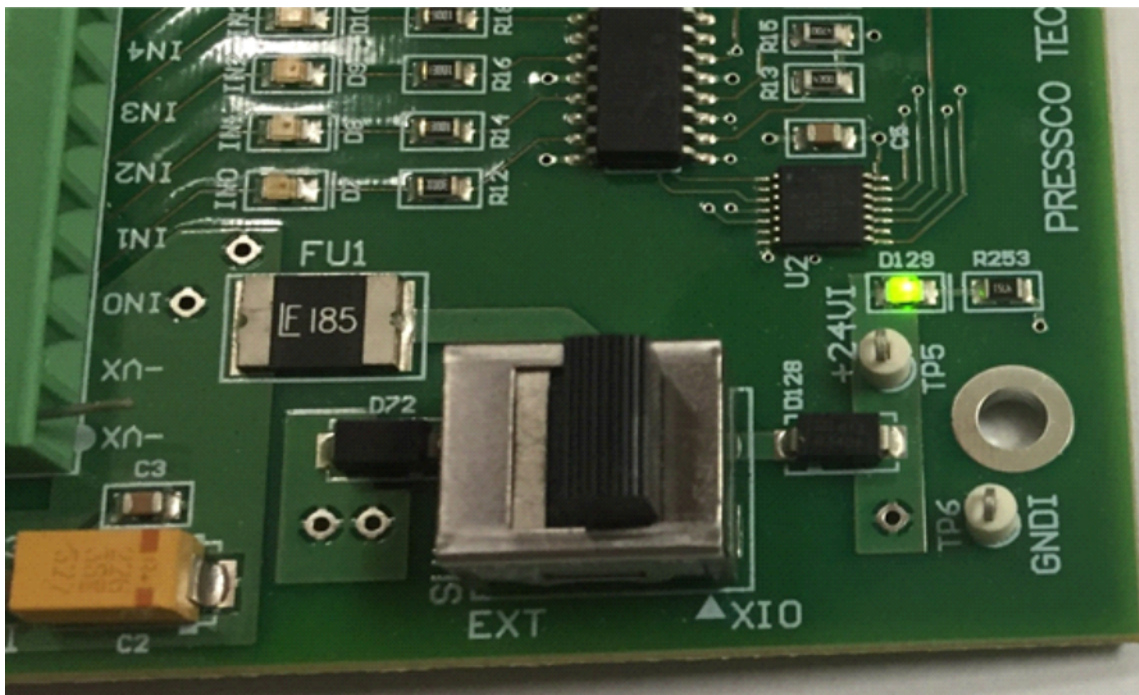

Figure 2 - Switch SW1 in the CTR position

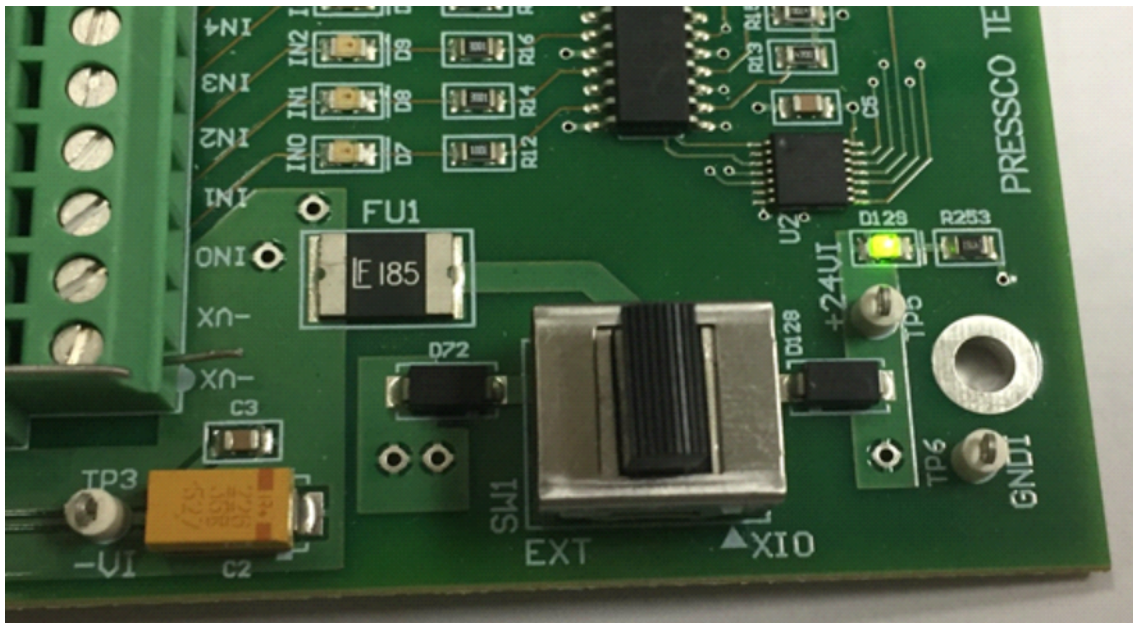
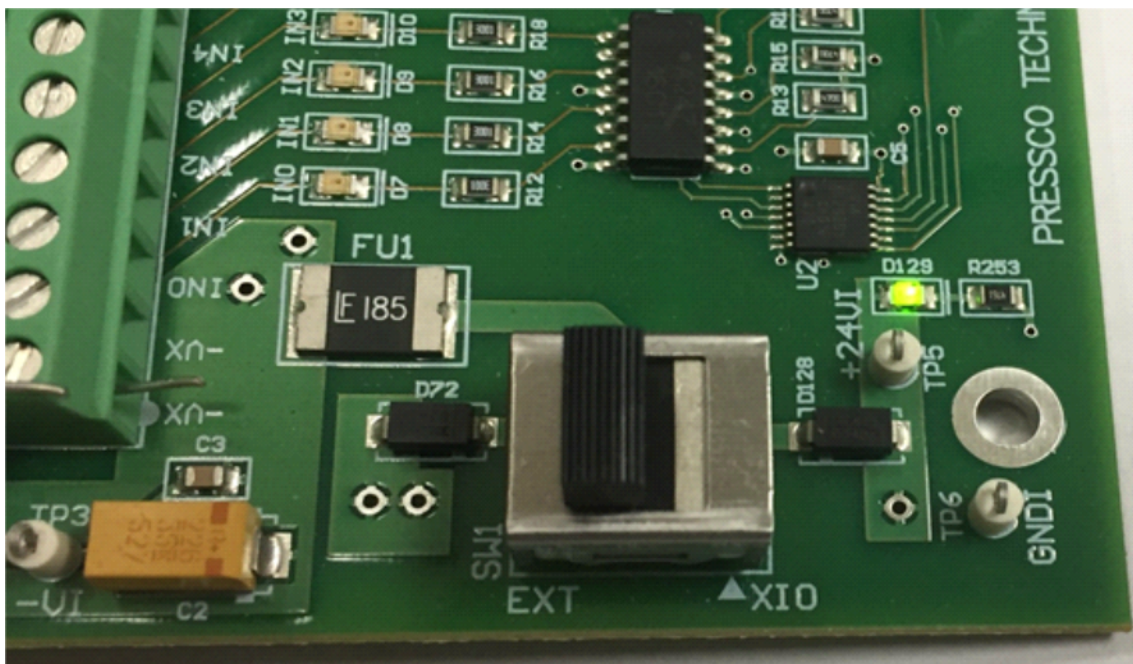

Figure 3 - Switch SW1 in the EXT position



Extended I-O Circuits S6

The following illustrations show typical input and output circuits you can use to communicate with your plant's PLC, or to connect external LEDs or light trees.

Specifications:

Chapter 9

- Minimum dwell time of the input device is 1.1 ms
- Maximum output load is 50 mA
- Default value of output pulse is 12ms. Some output signals, such as alarms, must be cleared on the Intellispec before they turn off.

Default timing of pulsed output

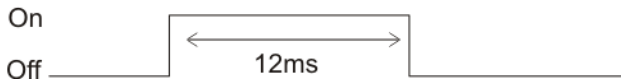

The following illustration shows a typical circuit that can be used to clear alarms.

CLEAR ALARMS - INPUT

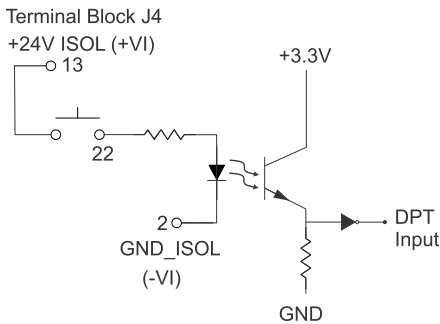

The following illustration shows a typical circuit that can be used for a group output.

GROUP 1 - OUTPUT

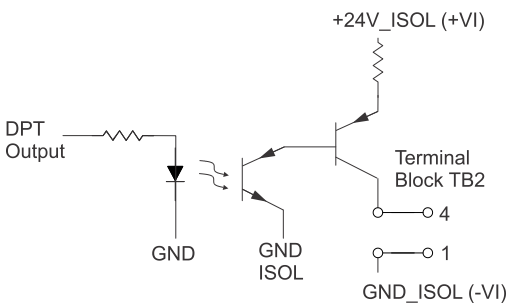

Extended I-O Configuration

Enable input or output signals to perform a function on the Intellispec system or monitor the production lane in your plant. These settings must be done for each Extended I/O board for each lane.

See also the sections about Extended I/O and Extended I/O Signals in the Intellispec Hardware Guide.



To get to this screen: From Lane or Sensor Overview mode, select Tools | Hardware Setup | Extended I/O Configuration.

This screen displays some of the inputs and outputs on the optional extended I/O board.

If one of the extended I/O ports is used it must be enabled here in the software, and the hardware must be connected appropriately.

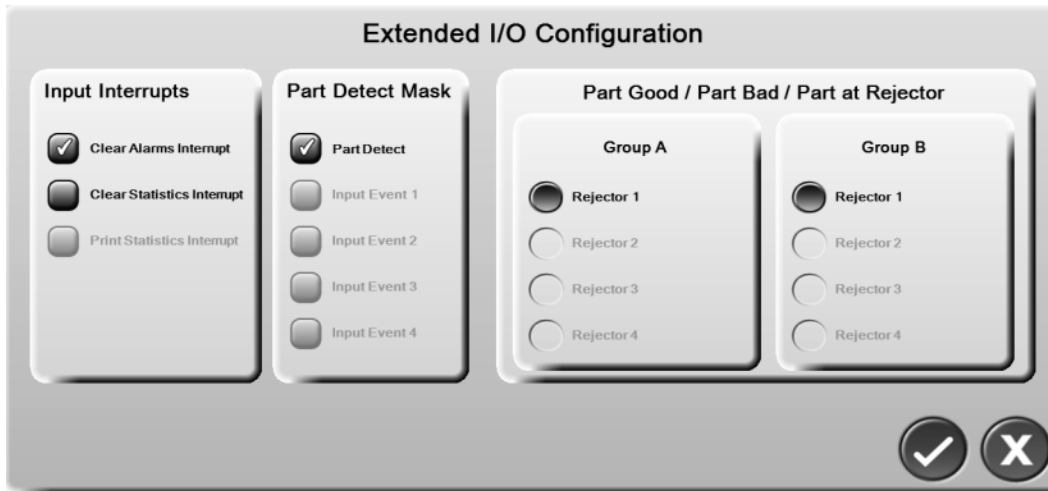

Input Interrupts

These signals produce an input pulse to the Intellispec to perform the following functions.

Clear Alarms Interrupt - Clear the lane alarms.

Clear Statistics Interrupt - Clear the lane statistics.

Print Statistics Interrupt - Print the lane statistics to the currently configured printer or file. See also Schedule Reports.

Part Detect Mask

Choose which Part Detect or other input events to trigger the Part Present output on the Extended I/O board. This is an OR function. Any enabled Part Detect signal or Input Event that goes active will activate the Extended I/O Part Present output.

Part Detect - The signal goes active when the sensor detects a part.

Input Event N - The Part Tracker board accepts up to five* input events (Part detectors or other sensors). Part tracking is always controlled by the Part Detect signal (Input Event 0). You might use other input events (1 - 4) in your system to trigger the Part Present output signal. *Only if your system has an 8-channel Part Tracker board. If your system has a 2-channel Part Tracker board, then only one Part Detect signal is used. The other input events are not available.

Part Good/ Part Bad/ Part at Rejector

Choose which rejector signal to activate the Part Good, Part Bad, and Part at Rejector signals on the Extended I/O board. After a part is inspected, the system determines whether the part is good or bad. As the part passes by Rejector 1, 2, 3, or 4, the Part Good/ Part Bad/ and Part at Rejector signals are activated on the Extended I/O board. There are two groups of Part Good/ Part Bad/ and Part at Rejector signals - Group A and Group B. You choose which rejector is associated with Group A and/or Group B. You can have both groups associated with the same rejector, if desired. See Extended I/O signals in the Intellispec hardware guide

Note: If your system has a 2-channel Part Tracker board, then the lane has up to two rejectors. If your system has an 8-channel Part Tracker board, then the lane has up to four rejectors.

Example 1 below

Group A is triggered when the part passes Rejector 2, and Group B is triggered when the part passes Rejector 4. The illustration below shows a basic block diagram with a conveyor with four rejectors. Those rejectors output a signal to the Extended I/O board, based on the Extended I/O configuration.

R = Rejector

PG = Part Good signal, Group A and Group B

PB = Part Bad signal, Group A and Group B

PaR = Part at Reject signal, Group A and Group B

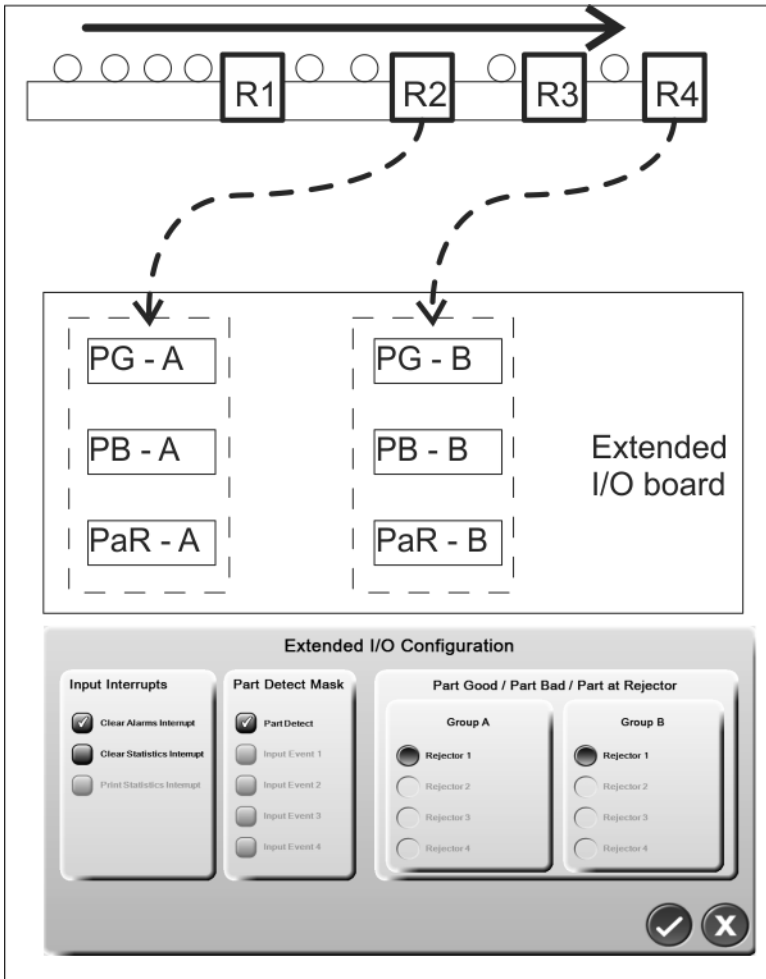

Example 2 below:

Group A is triggered when the part passes Rejector 2, and Group B is also triggered when the part passes Rejector 2.

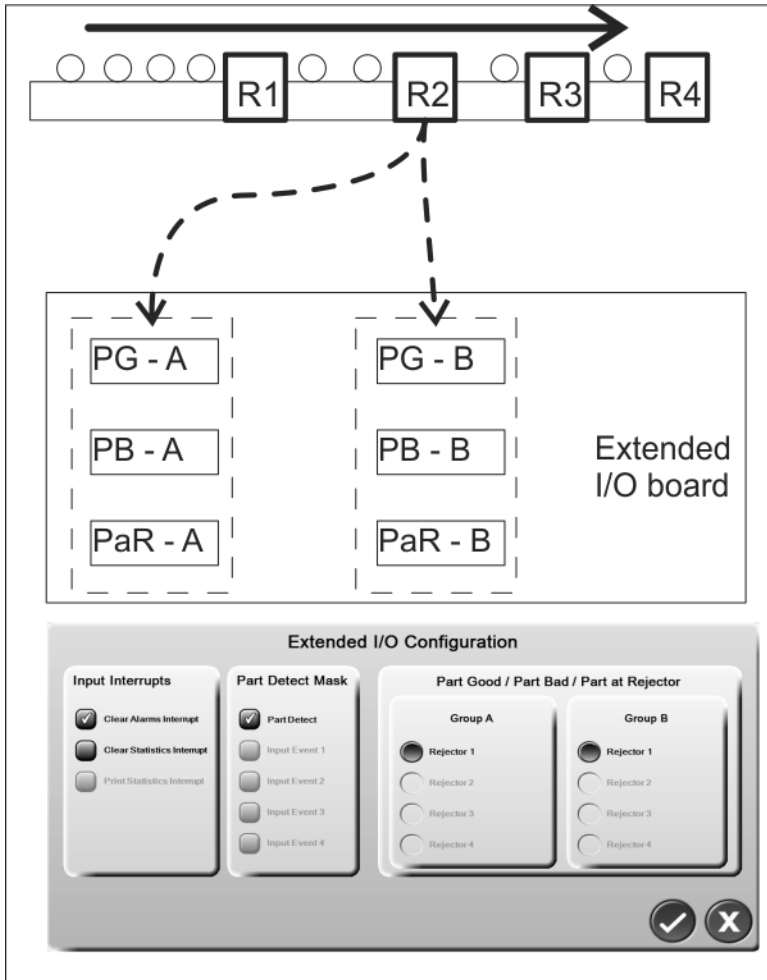

Chapter 10 Maintenance Frequency

Item	Description	Frequency
Observe proper rejection	Verify that defective parts are being rejected by inserting a known defective part through inspection	Daily
Observe Proper inspection	Verify that no stray parts are stuck in or near the inspection module or reject station	Daily
Observe Proper inspection	Verify that no buildup of dirt or contaminants has occurred on inspection module. Clean if necessary.	Daily
Observe Proper inspection	Verify that each camera's image is properly centered, focused, and properly lit. Adjust if necessary.	Daily
Glass surfaces	Clean with soft, clean, oil-free cloth dampened with glass cleaning solution	Daily
Plastic surfaces	Clean with soft, clean, oil-free cloth dampened with mild soap and water solution	Daily
Part Detect Sensor and Reflector	Clean with soft, clean, oil-free cloth dampened with mild soap and water solution. Wipe dry.	Weekly
Create a Support Package	Create a snapshot of your Intellispec settings.	Monthly
Acronis Backup	Create a full System Backup.	Yearly

Note: please refer to the manual for your inspection module(s) for maintenance procedures

Chapter 10







This page left blank intentionally

Maintenance

This instrument has been designed and tested in accordance with Publication EN61010-1 (2010) Safety Requirements for Electrical Equipment for Measurement, Control and Laboratory Use and has been supplied in a safe condition. The instruction documentation contains information and warnings which must be followed by the user to ensure safe operation and to maintain the instrument in a safe condition.

 **WARNING** - This product contains no operator serviceable parts. Refer servicing to qualified personnel. To prevent electrical shock do not open cabinet doors whilst power is connected.

When carrying out maintenance or repair work:

	Disconnect master switch. For switch locations, refer to the Power Up and Power Down section.
	Before starting the machine, ensure that no person is close to the machine.
	If maintenance or repair requires the disconnection or removal of safety or protection systems, this operation must be supervised by authorized personnel who must ensure the prevention of personal injury or damage to the machine. All machine movements must be performed with limited speed and limited movements.
	Maintenance or repair work on electrical components must be carried out exclusively by authorized, trained personnel. When running tests with power connected, you must strictly comply with the rules provided.
	Personnel working on higher parts of a machine must wear a harness and hook it on to the structure and must always move with extreme caution.
	Never perform lubrication or maintenance procedures on mechanical parts with the machine running.

LED Caution:

 **CAUTION** - Possible hazardous optical radiation from LEDs. Do not stare at lamps.

When returning the unit to service:

 **CAUTION** - Before switching on this instrument, ensure the power supply voltage is in the specified range.

Clean the Air Conditioner Filter

The filter should be cleaned once a month for best results. The filter is located on the side of the cabinet. Replace with a new filter when necessary.

Note: You may need to clean the filters weekly depending on plant conditions

Does your air conditioner have a filter?

Your system may not have a filter to maintain if the air in your plant is generally clean without oil or extreme dust.

- If your air conditioner has a filter, you should be able to see it through the lower air conditioner cover. It will be a gray metallic mesh filter. If yours has the filter, then clean it as instructed below.
- If your air conditioner does NOT have a filter, then you will just see a fan grill under the cover as seen in this photo. Instead of cleaning the filter, remove dust and debris through a vacuum or soft cloth.



Note: your system may be equipped with a stainless steel version of the air conditioner for wash-down systems. Maintenance is the same.

What you need to clean the air conditioner filter:

- Phillips head screwdriver
- Recommended: "RP Super Filter Coat Adhesive." Find this on the Internet or in a hardware store near you.

To clean the filter:

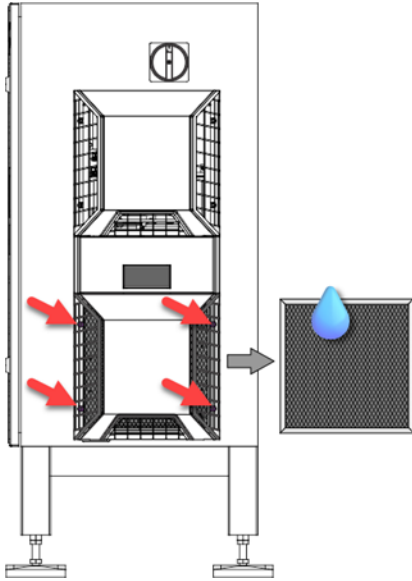

1. Loosen (do not completely unscrew) the four screws on the lower part of the cover.
2. Remove the bottom cover.
3. Remove the filter and clean it.
 - If the filter contains dry dust and dirt, rinse it in plain water
 - If the filter contains oily dust and dirt, clean it in soapy water, then rinse in clear water - DO NOT use caustic solutions
4. Dry the filter completely [placing it with a corner down will assure complete drainage].
5. Recoat the filter with "RP Super Filter Coat Adhesive." Spray both sides for best results.
6. Place the filter back inside the cabinet cover.
7. Replace the filter cover and tighten the screws on the lower cover.